

# MONITOR

→  
15

## Bender Remote Assist

A Bender Service:  
Safe – at short notice – anytime  
and from anywhere



iso685:

## The right solution for each application

Main features of the product family iso685



Knowledge and support network

## Remote Assist systems

### Answers for tomorrow

Bender participating in Fraunhofer Innovations Cluster  
"Power electronics for regenerative energy supply"

**BENDER** Group

# editorial



Dear Readers,

At the end of 2014 the Bender strategy was put through the test in several workshops. A significant result was that no change of the principal orientation of the strategy was decided. In other words: Bender will continue along the path they have been travelling for decades and continue to devote themselves to electrical safety. But also many adjustments and readjustments of strategy were defined in detail, which are to be implemented in the coming years.

The long-term strategy can be summed up in three words:

- 1. MATTER:** We want to focus on what is important for our clients, which creates added value. We want to ignore anything that does not help or bring any direct benefit to our customers.
- 2. FASTER:** In the coming years we want to work on being fast and to becoming an even faster company.
- 3. MASTER:** We want to remain Master in our market segment with competence and technological leadership. Master in the market segment: **M**onitoring to assure **A**vailability and **S**afety of **E**lectrical Systems.

With these three cornerstones we want to give you, our dear customer better support in reaching your future goals. In this MONITOR you can check practical examples and convince yourself that we are already on the way.

Yours

Dirk Pieler  
CEO

## IMPRINT

Bender GmbH & Co. KG.  
Londorfer Straße 65  
35305 Gruenberg / Germany  
Fon: +49 6401 807 - 0  
Fax: +49 6401 807 - 259  
E-Mail: [info@bender.de](mailto:info@bender.de)  
[www.bender.de](http://www.bender.de)

### Editorial staff:

Marita Schwarz-Bierbach  
Anne Katrin Römer

### Graphic & layout:

Natascha Schäfer, Dipl.-Komm.-Designerin (FH)  
[www.s-designment.net](http://www.s-designment.net)

### Copy-editing/text:

Michaela Heck M.A., Textwerk  
Timothy Hörl, [www.dreipass.net](http://www.dreipass.net)

**Photos:** Bender Archiv, S!Designment Archiv, Fraunhofer IWES, Senckenberg und Senckenberg – Traenkner, Bender Inc. USA, Bender Russland, PRO-MAC Polen, A. Varnhorn/B. Hartung  
iStockphoto: @sumos, @nadla, @ryasick, @stokkete  
@catenarymedia, @Peter Petto, @Teun van den Dries,  
Fotolia.com: @Sergey Nivens, @teracreonte,  
@VERSUSstudio, @Andrea Izzotti, @Martina Berg,  
@shockfactor – Thinkstock: @Jochen SandsiStockphoto:  
@sumos, @nadla, @ryasick, @stokkete  
@catenarymedia, @Peter Petto, @Teun van den Dries,  
Fotolia.com: @Sergey Nivens, @teracreonte,  
@VERSUSstudio, @Andrea Izzotti, @Martina Berg,  
@shockfactor – Thinkstock: @Jochen Sands

**Print:** Druckhaus Bechstein, Wetzlar

# content



<b>Remote Assist systems – knowledge and support network</b>	<b>04</b>
<b>Bender Finalist at the Innovation Award</b> of German Industry 2015	09
<b>Bender Remote Assist: Safe – at short notice</b> – from anywhere and anytime: A Bender Service	10
<b>Answers for tomorrow</b>	13
<b>INNOVATIVE PRODUCTS</b>	
<b>Main features of the product family iso685:</b> The right solution for each application	18
<b>Serie XM420-DW:</b> Special requirements, demand reliable measurement technology	21
<b>ISOMETER® iso165C:</b> The new insulation monitoring device (IMD) for unearthed DC drive systems	22
<b>ISOMETER® isoXX425:</b> The compact devices series with Modbus RTU interface	24
<b>COMTRAXX® COM465DP:</b> The New Gateway Generation	25
<b>TECHNICAL APPLICATION</b>	
<b>Fraunhofer IWES Northwest relies on Bender:</b> Safe operation: Constantly and worldwide	26
<b>The Stone Age meets modern network protection technology:</b> Naturmuseum Senckenberg	29
<b>Upheaval in health care:</b> Proven technology for electrical safety is now also finding its way to Mongolia	32
<b>Always travel safe with a reliable power supply:</b> United States Coast Guard has the right combination on board	35
<b>Bender UK</b> sets standard for operating theatre installations	38
<b>PRO-MAC:</b> A long lasting cooperation with Bender	42
<b>CUSTOMER PORTRAIT</b>	
<b>Schalt-Technik Huber</b> represents service and expertise	46
<b>EXHIBITIONS 2015</b>	
<b>INTERVIEW</b> with Dr Carsten Bepler Head of Legal Department	50

## Remote Assist systems – knowledge and support network

→ Page 04



The classic division in products and services has had its day. In the age of Industry 4.0 products and "Internet of things" based services are being merged increasingly to Smart Services. Can smart devices provide even more security by using smart service and by digitisation and networking? ...

## Answers for tomorrow

→ Page 13



As a long-standing member of standardization organizations, Bender is now also participating in a larger research cooperation encompassing industry, science and research, contributing its specialist know-how towards jointly managing the challenges of the electric future ...

## Schalt-Technik Huber represents service and expertise

→ Page 46



As a family company with almost 50 years experience, we know the difference between pure service and genuine partnership. Holistic energy management calls for individual concepts. Close cooperation and taking on your special wishes and needs is an absolute MUST for us when it comes to the distribution, control and monitoring of electrical energy ...





FEATURE

- SHOW BUSINESS
- NETWORK
- MUSIC
- CINEMA
- BUSINESS/FINANCE
- WORLD NEWS

```

12010111010101001
0010101010100101
110101011100101011
1101010020011011
111110110101110110
101101010101101
1111110001010111101010
10110101111
10101110101101010101
01100111110101
111111010101011010101
0110101011111111

```

NETWORK SEARCH

- PEOPLE
- FORUMS
- MAIL
- SHOP
- BUY
- SALE

WORLD

# Knowledge and support network

## Remote Assist systems

**The classic division in products and services has had its day.** In the age of Industry 4.0 products and "Internet of things" based services are being merged increasingly to Smart Services. Can smart devices provide even more security by using smart service and by digitisation and networking? The answer is: Yes. The development is towards more and more features on the connected devices. There is always less time for Network Monitoring available. Early detection of errors and fast troubleshooting is becoming less and less possible. In addition to the increasing number of smart devices there are more and more Smart Services on offer in order to safeguard the Industry 4.0 power supplies.

**Remote Assist Systems close this gap.**



## The principle Assist

### Smart Service – Connected know-how

Industry 4.0 and "Internet of Things" are the driving force for networking and Smart Services. What does this mean for the safety of the power supply? For the ever more complex systems more and more devices are needed. Machines and equipment always require more know-how. For the clarification of questions experts are needed more often. On-site service costs more, not only because of the travel involved. Just using the phone allows many questions to be only partially answered or not at all. The solution: Remote service or smart connected services, as they will be called in the future.

For questions a local expert can help. The reaction time is reduced if the assistance is immediately available on the phone. If the expert can see all the settings of the system himself via remote access, this can be done even more rapidly. With the wide variety of devices many different experts are required. If the manufacturer has a modern assist system, the analysis is carried out step-by-step and "switched" through to the respective expert. Troubleshooting and analysis of fault messages is cost-effective, prompt and quick due to this new user support. The setting up of device parameters and the optimisation of the machine often require no on-site engineer. Not having any travel expenses reduces the operation costs. More often than not an annual support contract is cheaper. As with mobile phones the so-called flat rate is the easiest way of billing. In this way the plant operator is ensured prompt and competent support.

### Secure collaboration

**For remote services there are different levels of security.**

The first level is the IT security. This ensures that a connection from the device to the service centre is established which can also go through the house internal network. A VPN-tunnel and outgoing connection provide for a secure connection.



## FEATURE

- ▶▶▶ The second level is the user security. This ensures that only authorised persons have access to the machine. This also allows authorised maintenance employees of the machine to access the machine remotely and help colleagues.

The third level are connection logs which if necessary show when and who had access. A further level is the support contract. It regulates everything necessary for this new type of support.



This multi-level security concept makes remote assist systems easy to handle built on remote platforms as a reliable and transparent technology right from the start. This allows the service engineer to work as he would be onsite.

Modern service platforms additionally check also the connection status. If there is an interruption of the connection then in cooperation with the staff of the machine operator the cause can be eliminated. This brings security for the company and ensures rapid response to questions. The question is not, "Is it secure?", but "What levels of security has the manufacturer taken into account?" If a remote contract is offered or the service provider has alternative remote general terms and conditions, then usually there is a sufficient security concept.

## Industry 4.0

Experts see in associated with digitisation change the starting point for the fourth Industrial Revolution (Industry 4.0). With Industry 4.0 (a future project in the high-tech strategy of the German Government, where initially the computerisation of manufacturing technology is supposed to be promoted) there is to be a large number of networked machines and devices in use, which have higher demands on the power supply. The machines are designed for higher levels of reliability. This means by using IT technologies as also requires a higher availability of the power supply system. Remote Assist offers a service support which fits these requirements.

Of course soon it will be common that the safe power supplies work together with this remote technology and the Smart Services. Remote Assist systems with good security and smart service concepts are currently coming on the market. First of all from innovative manufacturers.

## Internet of Things

While Industry 4.0 has its origin in research projects around the networked production, "Internet of Things" comes from the area of information and communication technology. With the "Internet of Things", as it is generally known, objects are becoming intelligent and exchange information online. This means therefore that methods, software and complexity are moving into machines and equipment. In the near future monitoring for more reliability, automatic alarms, apps, and evaluations will be a matter of course for all equipment. The new services will therefore grow rapidly. The next step for the connected services is the adaptation of ideas from the world of "Internet of things". The foundation for this will be modern remote platforms with Smart Services. This already means for the user today, that they need to get to know the new services being offered and to use them in order to benefit from future development.

## Introduce Connected Services

In order to get the benefits of the new Connected / Remote services, generally it is necessary to install a Service and Security Box as Gateway for the devices. This gateway connects the devices with the communication line to the central platform. These connections are then set-up in the central remote platform in preparation for rapid requests. This also includes the machine-specific documents being made available online. Alternatively each individual device can be connected.

If an expert from a manufacturer is required to answer questions then a telephone call is all that is required. With a few clicks he has access to the machine and can provide support. The settlement is carried out either for each case or by an annual service rate for all service matters that can be solved remotely. As with the mobile phone the so-called flat rate is usually the typical contract, which also includes additional services such as performance review and on-line documentation. In addition to the reduction in faults and consultancy, after the start-up period, consideration can be made about discuss-

„Remote Assist services are now being used **from the first day**. They assist to faster commissioning. Help with any uncertainties during the start-up period, and with the interpretation of parameters.“

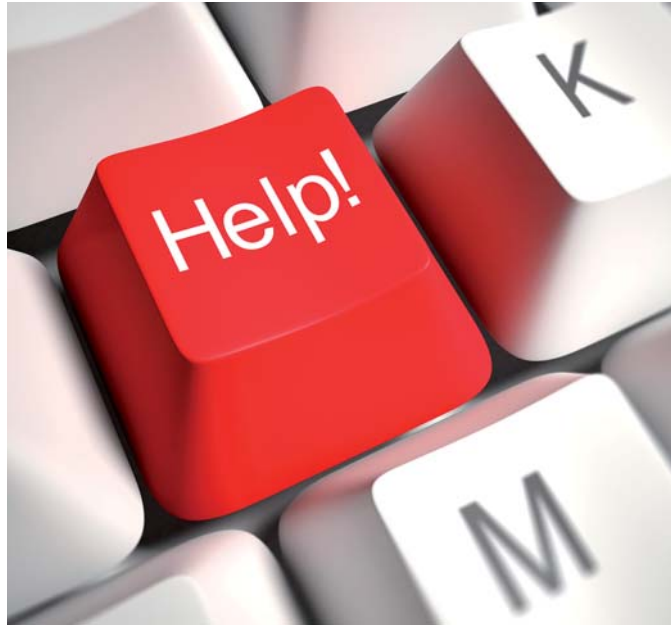

ing the provision of know-how in-house and the periodic inspection of machines performed remotely.

Remote Assist services are now being used from the first day. They assist to faster commissioning. Help with any uncertainties during the start-up period and with the interpretation of parameters. Indication there are faults will be much easier. Existing installations are often retrofitted for smart services to meet the increased demands due to a more stable power supply.

## What will change with the manufacturer?

The first that will change is the strategy. The provision of smart remote services is connected with investments in different areas. The objective is to offer the customer a more rapid service with smart additional functions. Prior to the introduction, it is necessary to invest in the so-called tickets, so that longer-lasting clarifications can be tracked. The result will be an increase in service quality. This allows employees to solve repetitive cases more quickly. In addition to





## FEATURE

▶▶▶ the innovations with the devices the future will also bring the evaluation of the innovative power of the services.

Manufacturers that introduce Smart Services, do not only invest in the Gateways such as the Service and Security Box, but also in the changes in the process and personnel, in order to ensure the rapid and

smooth expert service. In addition, there are training courses for employees and the introduction of software to support the connections and new internal processes. This preparation with a wide variety of test runs will take quite some time. For the further development of the Smart Services each new generation will have additional features built-in. Connected services will be featured in every device.

## CONCLUSION

Connected services such as Remote Assist are a step into the "Connected World" by the "Internet of things" and Industry 4.0. With this step the innovative manufacturer begins a new smart service product family, which simplifies the troubleshooting and consultancy for the machine user, those carrying out the commissioning and the service engineer. Increasing complexity and the provision of well-trained employees are the challenges with which the new approaches are easier to use.

The security architecture of the new service offers are in accordance with the latest findings and allow the machine operator full utilisation.

In addition to innovative devices and systems, innovative Smart Services are now beginning to appear. These innovations will lead to discussions at all levels. The benefits are obvious and the usual reservations against anything new will be quickly overcome.

Since many functions and concepts have been tried in other industries, the manufactures are well advised to have their development and service departments use these findings to a large extent. Then there is nothing to stop a rapid market introduction.

Innovations that bring more security, comfort, cost reduction, and new procedures for modern devices are timely and necessary in a highly technical country. Service innovations, built on communication technologies, are still quite unusual in many branches. However, it is now important to recognise their undisputed advantages and integrate them into daily routine. ■

*Dipl. Ing.(FH) Karl-Heinz Sauter  
Managing Director of Karl-Heinz Sauter Services and Consulting GmbH  
and the founder of the RemoteServiceForum*



# Bender Finalist at the Innovation Award of German Industry 2015



With the insulation monitoring device iso685 for unearthed electrical systems, Bender was one of the best four and thus reached the final in the category "Medium-sized companies".



**The innovation award of German industry – "First innovation prize of the world®" looks back on a long tradition and has a high penetration in all sectors and regions of the economy.** It is announced for the four categories of "Large enterprises", "Companies with innovative personnel concepts", "Medium-sized companies" and "Start-up companies". The award is under the auspices of the Federal Ministry of Economy and Energy, as well as the Federal

Now for the 34<sup>th</sup> time the most important scientific, technical, entrepreneurial and intellectual innovations of German industry were awarded in Frankfurt am Main on 21 March 2015. The awards for the winners and finalists were awarded to companies at a festive Gala in the cultural House of the Frankfurt Palmengarten, the "most beautiful ballroom of the city".

Of the 270 candidates a total of 16 companies made it to be among the finalists of the 34<sup>th</sup> round of the competition. Bender was nominated as one of four finalists for the prize "Medium-sized companies".

Bender applied with the insulation monitoring device ISOMETER® iso685 for unearthed power supplies. The company's founder, Walther Bender, was the inventor of the insulation monitoring in unearthed systems and he patented this technology for the first time in 1939. Bender launches an innovative and trend-setting product generation with the iso685-D, which is used for insulation monitoring and sets the standard with respect to reliability, measurement methods, usability and design corresponding to the latest state-of-the-art. In addition to the core-function of continuously monitoring the insulation of a system against earth, the iso685 family offer many additional features that can help to increase the level of safety and save costs.

Organisers of the innovation award are the F.A.Z. publishing house and the main partner the Frankfurter Allgemeine Zeitung GmbH. Additionally there are other key partners. ■

*Marita Schwarz-Bierbach, S-COM*

## WE CONGRATULATE THE 2015 WINNERS:

**Large Enterprises:** KUKA AG / lightweight robots

**Innovative Personnel Concepts:** Merck KGaA / Initiative Innospire

**Medium-sized Companies:** ISRA VISION AG / "Plug & Automat"

**Start-up companies:** TerraNovaEnergy

**Bender Service: Safe – at short notice – from anywhere and anytime**



## Bender Remote Assist

The service product "Bender Remote Assist" is a web-based management system for monitoring and analysing the electrical installation, as well as proactive detection of the maintenance needs **from any location.**

**Bender Remote Assist** will be offered within the scope of the service contracts from Bender. The basic idea is, high-quality service through a web-based service platform, which meets the highest technology and safety standards. On the other hand, due to the ever increasing complexity of devices and systems, it is necessary for the future to ensure consistent high safety and consultancy. A component of the Bender Remote Assist is the service platform, which can be called as a Web application on all common browsers. It is used as a safe and reliable link when remotely accessing electrical installations.

In this case there is no end-to-end, direct connection, between the network of the user and that of the system operator. They are completely separated from each other by the Bender Remote Assist. Every connection is established separately and is valid only for the user requesting the connection and for the selected electrical installation.



The rights management of the service platform ensures that the connection is only possible, if the user has the necessary rights. The user cannot obtain knowledge or information from any other installation. Data security and data protection have highest priority. All platform and access activities to the system are logged and can be called up at any time via the Web interface or, if you wish, it can be sent automatically by email. The Link Check ensures continuous monitoring of the installation reachability and therefore guarantees that all functions can be used at any time.

Bender Remote Assist is therefore one of the most secure and modern interconnect technologies currently available.



Fig. 1:  
Visualisation





Fig. 2: Gateway COM700RA

▶▶▶ The system consists of two elements: the service platform and the Gateway COM700RA. The installation only requires the integration of the Gateway COM700RA in the installation to be monitored. Then the full range of functions of the Bender Remote Assist system can be used. Due to the flexible system architecture and, thanks to its experienced IT-specialists Bender is in the position to implement any special customer requirements.

The extension of the installation with Bender Remote Assist opens up a wide-ranging set of new services and added value.

Due to the continuous system monitoring by Bender product experts the operational reliability increases and the increase in knowledge can be considerably extended. So, in addition to the reactive preventive maintenance a regular monitoring and analysis for proactively identifying maintenance needs is possible. If an error or a technical problem occurs, information is sent immediately to the appropriate certified system experts. Directly after receiving the message from the system a Bender employee can remotely log into the customer system, implement a

remote diagnosis, start a failure analysis and offer immediate support. Our network of experts ensures that the complete Bender know-how is available, always and everywhere. Therefore Bender is in the position to find the problem quickly and either start immediately with rectification or to take the necessary measures to start the rectification. This means shorter reaction time, time savings, rapid assistance with acute questions and less travel time.

If the problem cannot be solved remotely straight away, then ordering and the dispatching of the necessary spare parts are possible or a technician can be on the way to help locally.

With the Bender Remote Assist, service is safer, faster and more customer-friendly. Thus, the service quality is significantly improved, increased system availability and safety increased, ultimately a more stable operation is guaranteed. ■

B. Eng. Michael Breuer, S-SER

Fig. 3:

Road map

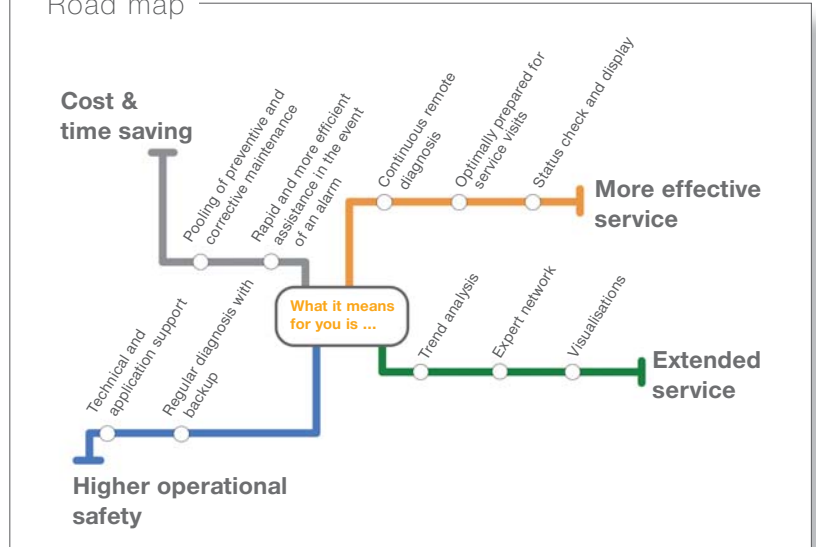



**Bender participating in**  
 FRAUNHOFER INNOVATION CLUSTER  
 "POWER ELECTRONICS FOR REGENERATIVE ENERGY SUPPLY"



## Answers for tomorrow

**As a long-standing member** of standardization organizations, Bender is now also participating in a larger research cooperation encompassing industry, science and research, contributing its specialist know-how towards jointly managing the challenges of the electric future. The goal of the Fraunhofer Innovation Cluster is to find answers to the issue of how the power electronics in wind turbines can be made less fault-prone, more efficient and less expensive.

The Fraunhofer Society sees one of its key tasks in transferring new scientific knowledge into innovations that benefit the economy and society. Under the "Pact for Research and Innovation", the Fraunhofer Society has taken on the task of devising Innovation Clusters and turning them into practical reality. The primary purpose of the Innovation Clusters is to contribute to the further development of already existing strengths. Cooperations of this kind set themselves clear targets and pool the specific capabilities of business enterprises, universities, non-university research partners and the Fraunhofer Institutes (see Fig. 1).



**Fig. 1:** Innovation cluster involving universities, Fraunhofer institutes and industrial partners

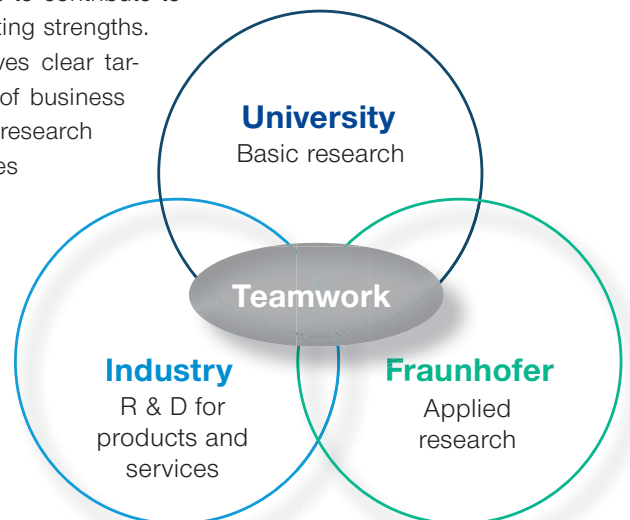
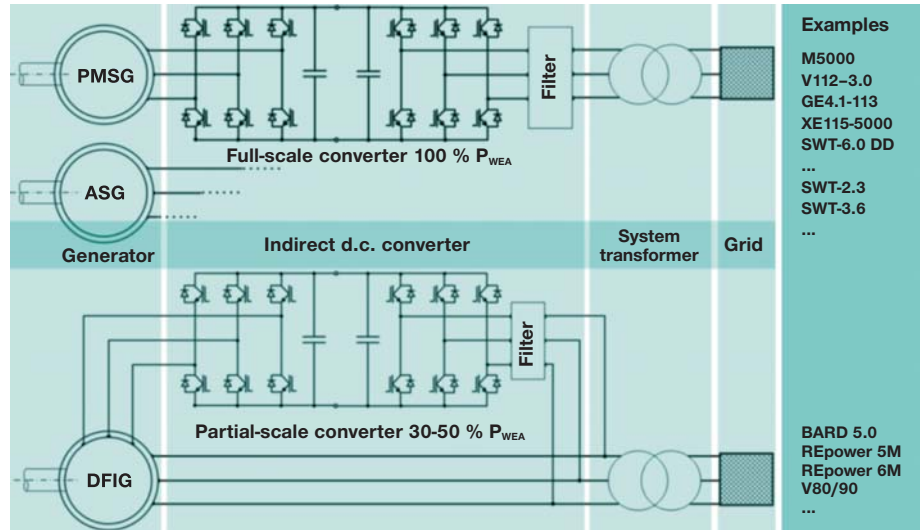



Fig. 2: Connection of wind turbines to the power grid at mains frequency.



▶▶▶ The collaboration leads to pooling and further development of the knowledge and skills of the parties involved and to better coordination of their activities. The close involvement of the university partners also ensures that the most up-to-date research results can also be consistently incorporated.

### The energy question

The worldwide growth in energy demand, the finite nature of conventional energy sources and the increasing warming of the climate make rapid progress towards sustainable energy supply and efficient energy use essential. A central role in this process will be played by the renewable energies. In the development of the renewable energies, the use of wind as an energy source will play a central role in the move towards an economically viable and climate-compatible energy supply.

In the last ten years, assisted by the public funding provided through Germany's Renewable Energies Law ("EEG"), the use of regenerative energy in Germany has experienced a huge development. Wind turbines in particular, with a total installed capacity of 31 GW, already cover a significant share of energy consumption in Germany, namely 11% (figures for the end of 2012). Wind energy currently supports around 100,000 jobs throughout Germany. In particular for the German economy, therefore, the further development of regenerative energy use is a strategic investment for the future.

### Key technology for the future

Power electronics has evolved into a key technology of the 21st century. Power-electronic frequency converters can also be found today in nearly all modern wind turbines. As the link between the generator and the system transformer, the purpose of the power electronics is to enable the wind turbines to connect up to the power grid at the mains frequency (cf. Fig. 2). As well as exacting demands to be met by the quality of the current fed into the

grid and to ensure the provision of reactive power in normal operation, there are detailed requirements on how a wind turbine must behave dynamically in the event of grid malfunctions in order to exert a stabilizing influence on the grid.

### Research and development

The Innovation Cluster “Power Electronics for Regenerative Power Supply” is aimed at the development of power electronic systems for regenerative energies in particular for use in existing and future wind turbines so as to make them less fault-prone, more efficient and less expensive. As initial R&D activities on the part of the Innovation Cluster, two lead projects are being pursued in the German federal states of Schleswig-Holstein and Lower Saxony:

As a company working the field of measuring technology and condition monitoring, Bender’s involvement in Lead Project B (Innovation Cluster Lower Saxony), “Reliable power electronics for wind turbines”, is especially important for the skills and technical know-how it can provide in the area of condition monitoring.

One of the major challenges is that the power electronic components, which are of such central importance for the functioning of wind turbines, are increasingly dominating the fault statistics. Recent studies<sup>1</sup> have shown that while gearbox faults accounted



Fig. 3:

Key focuses of the lead projects in Lower Saxony and Schleswig-Holstein

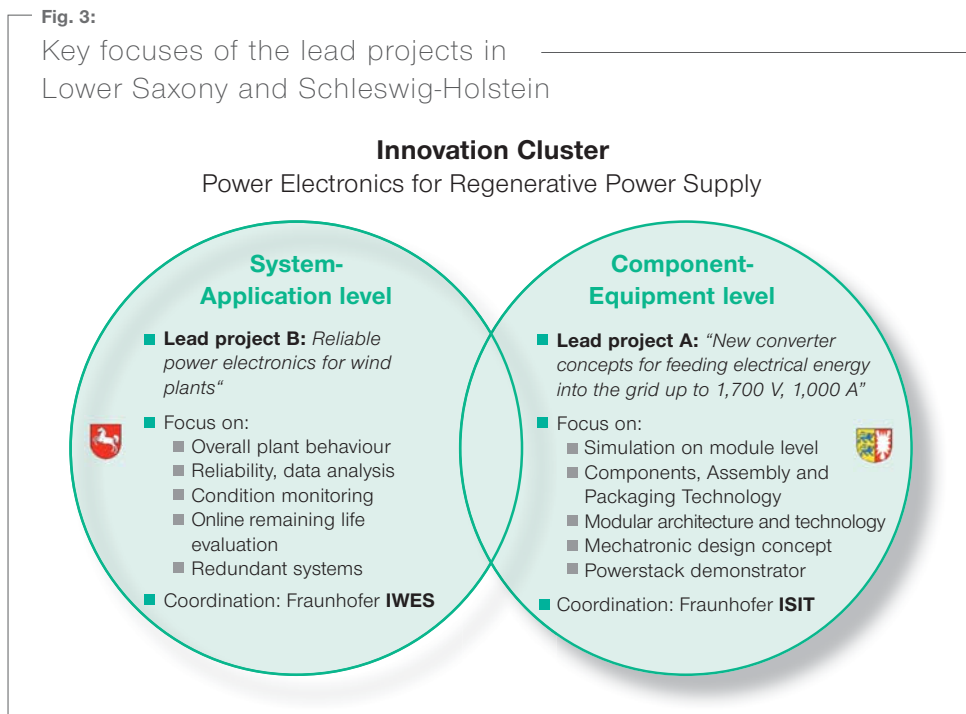

<sup>1)</sup> M. Wilkinson, B. Hendriks: Report on Wind Turbine Reliability Profiles, »Reliawind« project report, Deliverable D.1.3, 2011

▶▶▶ for a share of only around 5% of breakdowns, around three times as many breakdowns and no less than 18% of all damage-related downtimes were due to the frequency converter system (see Fig. 4).

**FIG. 4:** Share of various plant components in total failure frequency (top) and downtimes (bottom);

Data: [Reliawind-Projektbericht Wilkinson and Hendriks (2011)]

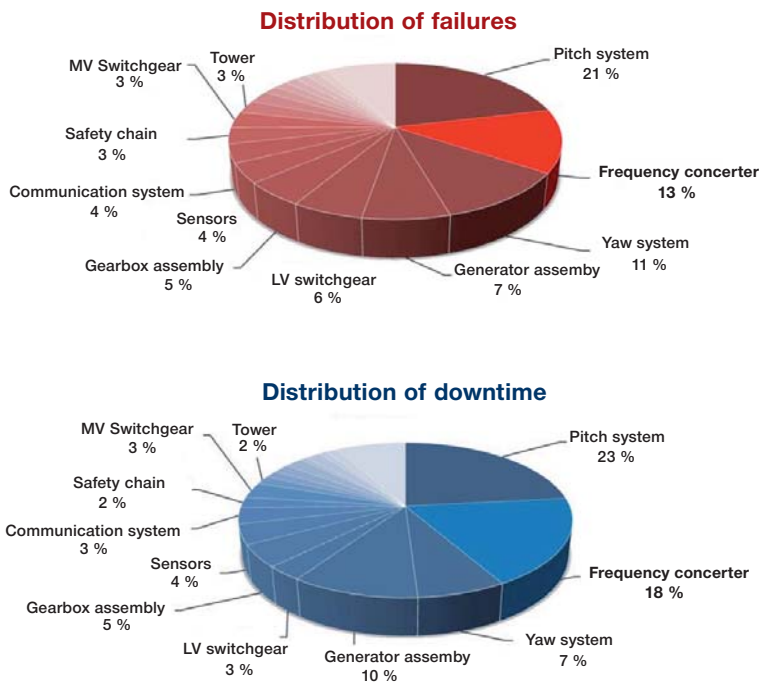

### Electrical faults as a cost driver

Therefore, faults affecting the power electronic components of wind turbines, and especially the converters, are a significant cost driver during the plant's operational life in terms of both the repair and/or replacement costs and also, in many cases, the resulting yield losses. And even more serious than in the case of land-based wind farms is the negative impact on system availability, and hence on earnings, of offshore wind farms. Here, the average downtime until repair tends to be markedly longer due to the restrictions on accessibility caused by the ambient environmental conditions.

Initial investigations confirm that the frequent failure of converter systems in wind turbines is both a manufacturer problem and a general topological problem<sup>2</sup>. However, analysing the causes is a complex process and is rendered more difficult by the often severe damage to the power modules.

### Currently no monitoring of electrical systems

At the present time, condition monitoring systems (CMS) for the early detection of faults are generally only used in wind turbines for monitoring the mechanical drivetrain components (e.g. gearbox, clutch, brake or rotor shaft). These systems frequently help to prevent serious damage, knock-on damage and lengthy downtimes. However, there are no comparable systems available for the electronic components in wind turbines. These components therefore tend to fail suddenly, quite often accompanied by an explosion and hence the associated risk of total loss through fire. The additional condition monitoring of electronic components could sharply reduce the financial effects

<sup>2)</sup> K. Fischer, T. Stalin, H. Ramberg, T. Thiringer, J. Wenske, R. Karlsson: Investigation of converter failure in wind turbines, »Confail«-Projektbericht, Elforsk Nr. 12:58, Stockholm, November 2012



of unforeseen damage and, in conjunction with coordinated preventive servicing and maintenance strategies, minimize the number of such events.

**In light of these facts, the following objectives have been defined for the Lower Saxony-based Lead Project B “Reliable power electronics for wind turbines”:**

- Investigation and identification of relevant causes of failure and failure mechanisms, and development of solutions to improve reliability
- Development of approaches for the early detection of changes of condition in power electronic components
- Understanding of the real environmental conditions and dynamic loads on frequency converters and the development of a basic specification specifically for wind turbine converters.

**The work under Lead Project B is broken down into the following work packages:**

- Analysis of causes of failure, and enhancement of reliability
- Condition monitoring and preventive maintenance
- Development and validation of models
- Development of innovative fault-tolerant system concepts.

We at Bender are proud to be involved in such an important and path-breaking research project, the results of which will benefit the industry as a whole and strengthen its technical market leadership in the field of wind energy and potentially expand it still further. ■

*Dipl.-Ing. Dieter Hackl, T-MIS  
Timothy Hörl, DREIPASS*

## ALL PARTNERS CURRENTLY PARTICIPATING IN THE CONSORTIUM:

### Science/Research:

- Leibniz Universität Hannover, Institut für Antriebssysteme und Leistungselektronik (IAL)
- Fraunhofer ISIT
- Fraunhofer IWES

### Industry:

- Availon GmbH
- Basler Versicherungen
- Bender GmbH & Co. KG  
Technisches Büro Nord in 28790 Schwanewede
- EWE AG
- FeCon GmbH
- Gothaer Allgemeine Versicherung AG
- ITEC International GmbH
- juwi Operations & Maintenance GmbH
- Leine Linde Systems GmbH
- PNE WIND AG
- SSB Wind Systems GmbH
- SEMIKRON International GmbH
- Suzlon Energy GmbH
- Vattenfall R&D
- Woodward Kempen GmbH
- wpd AG
- Zopf Energieanlagen GmbH

**FOR MORE INFORMATION, GO TO:**

[www.power4re.de](http://www.power4re.de)

INNOVATIVE PRODUCTS

**Main features** of the product family iso685

**THE POWER IN ELECTRICAL SAFETY<sup>®</sup>**

# The right solution for each application



**With the insulation monitoring device iso685-D** Bender is counting on an innovative series of insulation monitoring devices, that are state-of-the-art when it comes to reliability, measurement techniques, operability, and design. In addition to the core function, the possibility to continually monitor insulation of a network against earth, the new variants of the iso685 family offer many additional features that can help to increase the safety level and save costs.



Tab. 1:  
Summary of the variants

FEATURE	VARIANT	iso685-D	iso685-D-B
isoGraph		Yes	Yes
Measurement of $U/f/C$		Yes	Yes
Digital inputs and outputs		Yes	Yes
Measurement profiles		Yes	Yes
History memory		Yes	Yes
Modbus TCP		Yes	Yes
Webserver		Yes	Yes
ISONet		No	Yes
Function for insulation fault location with automatic adaptation to system parameters		No	No
Triggering on residual voltage		No	No

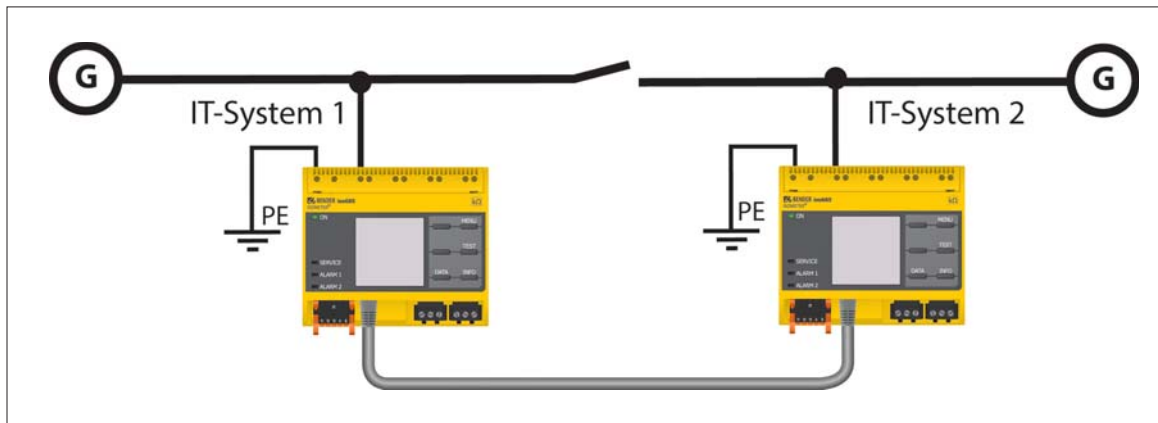

Bender solutions allow simple design of complex and/or coupled IT systems using the ISONet function for controlling the measuring authorization of several iso685-D-B. This has the advantage that no auxiliary contacts for a coupling switch is required.

## Characteristics of all devices

All variants feature a commissioning wizard, as well as a voltage, frequency and capacitance measurements. Furthermore, all have a permanent coupling monitoring, a buffered real-time clock with history memory and measurement profiles for different applications and the isoGraph for representation of the insulation resistance over time. Using digital inputs and outputs there are several ways of controlling the iso685 and to report errors. Since the operating concept of all variants of the iso685 product family is the same, the effort required for device training is greatly reduced.

Furthermore, the device iso685 has a Modbus TCP interface, which allows read out and parameter setting via a controller. Simple register access allows rapid implementation of visualisations.

An integrated web server keeps all the important measurements and device parameters ready. This allows remote access of the ISO685 from a computer, Smartphone or tablet which can then be easily setup and read out.

## Variant iso685-D-B

As a result of the measuring procedure several insulation monitoring devices can interfere with each other, and in accordance with IEC 61557-8 in an unearthed system (IT system) only one insulation monitoring device is allowed to be present. There are applications where redundant systems each with an insulation monitoring device are operated to 80% separately. If these systems are now connected together with a coupling switch then there are several insulation monitoring devices in one IT system.

The variant iso685-D-B is suitable for application in coupled systems. Via an internal network isolating switch the iso685-D-B can actively and independently separate itself from the monitored system. This allows several insulation monitoring devices to be used in a coupled system, without being influenced by closed coupling switches. Bender names the function ISONet. Bender uses the optional function REDC (Remote Enabling and Disabling Command) described in the product standard IEC 61557-8:2014 and is implemented through the integrated Ethernet bus. All iso685-D-B devices in the ISONet are connected together via Ethernet and regulate the measurement sequence automatically. This allows up to 20 coupled IT systems to be in one ISONet operation. Furthermore the Ethernet interface allows the design of



## INNOVATIVE PRODUCTS

►►► larger systems, which communicate with the series COMTRAXX® Gateways. This allows all measured values and parameters of different iso685-D-B devices to be locally controlled, summarised and visualised via a Gateway.

### Variants iso685-S + FP200 iso685-S-B + FP200

All variants listed in table 1 are with identical characteristics and are deliverable without an integrated display in combination with an extra display for the assembly in control cabinet doors. Two different installation variants allow a flexible integration of the devices into the front of a control cabinet.

The display panel FP200 is mounted in the front using retaining clips. The displayless base units iso685-S or iso685-S-B are attached to the mounting plate or the top-hat rail and are connected to the FP200 via the supplied RJ45 cable. The Indicator of the device is therefore located in the control cabinet

front, without having to route the system connection with up to 1,000 V in the control cabinet front. Despite the different installation the operation and behaviour correspond to the variants with displays.

There is the possibility for retrofit applications to fit the displayless base unit, iso685-S or iso685-S-B on the rear of the FP200 mounted on the control cabinet door. This allows the replacement of existing IRDH375 installations to be done easily.

### W-Variants

Additionally some variants of the iso685 family can be delivered for increased climatic and mechanical requirements. These are suitable for extreme operating temperature of  $-40...+70\text{ }^{\circ}\text{C}$ , with a climatic class of 3K5 and a mechanical class of 3M7 when being operated. The variants are marked with W for extreme operating conditions after the number 685 (iso685W-D).

### Variant isoRW685W-D

The variant isoRW685W-D, specially adapted for rolling stock, is additionally tested according to DIN EN 50155 and is also suitable for operating temperature from  $-40...+70\text{ }^{\circ}\text{C}$ , however for climatic class of 3K7 and a mechanical class of 3M7 when being operated. Therefore the isoRW685W-D completely fulfils the necessary requirements concerning EMC, temperature, climate and the mechanical class for use in railway applications. ■

*Dipl.-Ing. Jörg Irzinger, T-MIS*





## The series XM420-DW for EXTREME environmental requirements

### Special requirements, demand reliable measurement technology

The use of instrumentation in areas with highly fluctuating or extreme temperatures, high (air) humidity or at a higher vibration and shock loads or equipment creating heavy vibration or shocks is not uncommon. For these applications which require use under difficult to extreme conditions Bender has designed the measuring and monitoring relays series XM420-DW and guarantees precise measuring results under such conditions.

The relays are very resilient and are suitable to be used for the most diverse applications in extreme conditions and work even under the most difficult environmental conditions. They are resistant against humidity, shock and vibration according to DIN EN 50155 and can be operated in a temperature range from -40 to + 70° C (for a short time up to + 85° C for 10 minutes). Standardised tests according to DIN EN 60068-2-6 and DIN EN 60068-2-27 confirm a vibration resistance of 4 g and a shock resistance of 30 g. At the same time, the devices offer additional protection from interference pulses. Due to any increased resistance to EMC interference and a lower EMC emission a smooth operation of production systems and anything similar is ensured.

The measuring and monitoring relays of this series XM420-DW are equipped as standard with two alarm relays each supplied with a changeover contact. To ensure a simple conveyance or transfer of measured values to the measurement, control and regulation systems the devices are additionally equipped with standardised analogue interfaces (4 - 20 mA, 0 - 10 V). Furthermore, there is no falsification of measured values due to galvanic separation. ■

Dipl.-Ing. Marc Euker, T-MTS

## INNOVATIVE PRODUCTS



### PRODUCT FEATURES

- Designed according to flammability Class UL 94v-0
- Adjustable delays for start-up, response and release
- Digital measured values display via LCD
- Test/reset button internal/external
- Selectable N/O or N/C operation and fault storage
- Continuous self monitoring
- Password protection for device settings
- Push-wire terminal (two terminals per connection)
- 2-module enclosure (36 mm)

### IDEAL FOR DEMANDING APPLICATIONS SUCH AS:

- high shock loads
- high vibration loads
- extreme humidity/ice formation
- heavy contamination
- heavy temperature fluctuations (wide temperature range).

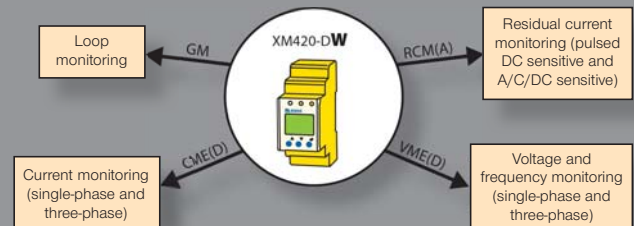

### The device series have the following approvals:

CE, UL and Lloyd's Register.

## INNOVATIVE PRODUCTS

ISOMETER® iso165C überwacht den Isolationswiderstand



## The new insulation monitoring device (IMD) for unearthed DC drive systems (IT systems) in electrical vehicles

The ISOMETER® iso165C monitors the insulation resistance between the active HV components of an electrical drive system ( $U_n = \text{DC } 0 \text{ V} \dots 600 \text{ V}$ ) and the reference earth (chassis ground).



**The patented measurement technology** is used to monitor the condition of the insulation on the DC side as well as on the AC motor side of the electrical drive system. Any existing or imminent insulation faults are reported reliably, even there are high levels of interference that can be caused by motor control processes (e.g. acceleration and energy recuperation). Due to its space saving design and optimized measurement technology, the device is optimized for use in hybrid or fully electric vehicles.

The ISOMETER® iso165 is assembled with three connectors. To achieve internal galvanic separation, connector 1 is connected to low-voltage (LV) areas and connectors 2 and 3 are connected to the HV areas in the car environment. The device meets the increased automotive requirements with regard to environmental conditions (e.g. temperatures and vibration, EMC). The iso165 CAN interface allows it to integrate seamlessly into an existing CAN environment.



The iso165 consists of two main components, the Vehicle Interface Controller (VIFC) and the Insulation Monitoring Controller (IMC). The VIFC consists of a microcontroller with a UART communication interface that translates and forwards requests from the HS-CAN bus transparently to the IMC. The corresponding IMC responses are returned to the requesting instance via the HS-CAN bus. The VIFC supervises the running state of the IMC via a signal known as "Alive", and internally and cyclically requests the insulation value and the running state of the IMC. The results are cyclically sent as an informal message via the HS-CAN bus. The IMC consists of the HV connectors with HV coupling relays, the measurement circuit and a microcontroller to analyse the measurement results. It generates internal alarm information from the measurement results, which is coded to produce the "Alive" signal mentioned previously. This signal is transmitted in parallel with the measurements and status information to the VIFC and from there over the HS-CAN bus. The IMC is galvanically separated from the car environment.

On initial power up, the ISOMETER® iso165 does not carry out any measurements until communication between the VIFC and IMC has been established. In addition, the HV coupling relays of the



ISOMETER® iso165C

HV1 voltage path are, by default, open and therefore no valid measurement of voltage HV1 and the insulation resistance is possible until these relays are closed by an external command. Once communication has been established between the VIFC and IMC and the HV1 path relays closed, the iso165 can immediately start measuring voltages HV1, HV2 and the insulation resistance.

## COMPACT – INNOVATIVE – SAFE

The ISOMETER® iso165 generates a pulsed measuring voltage that is superimposed on the IT system by the terminals T\_31\_E/KE (chassis). Because the connection between the terminals E/KE and the chassis ground (T\_31) is continuously monitored, it is necessary to install two separated conductors from terminals T\_31\_E/KE to chassis ground. ■

*Dipl.-Ing. Frank Mehling, T-MIS*

## INNOVATIVE PRODUCTS



## The compact devices series ISOMETER® isoXX425 with Modbus RTU interface

The new compact series of the insulation monitoring device ISOMETER® iso425 monitors the insulation resistance of unearthed AC, AC/DC and DC power supplies (IT systems) in accordance with DIN EN 61557-8 (VDE0413-8), and IEC 61557-8. Measurement is safe and reliable, even under difficult circumstances. The separate supply voltage also allows a separate monitoring in deenergised systems.

The devices can be operated with normally available supplies in switching cabinets using a universal power supply ranging from AC 100...240 V or DC 24...240 V.

Two separately adjustable response values/ alarm relays enable early and separate messages, long before the electrical installation reaches a critical condition. If the insulation resistance exceeds the release value (response value plus hysteresis), the alarm relays switch back to the starting position. The LC display allows the latest measured values as well as the alarm messages to be displayed. Parameters are assigned to the device via the display and the front panel control buttons, as well as through the RS-485 interface.

This compact series is used in the **following applications**:

- Photovoltaics with the **isoPV425**
- Electro-mobility in the DC charging technology with the **isoEV425**
- Railway technology with the **isoRW425**.

### Modbus interface

All devices are now also available with Modbus RTU interface. A change over of the BMS interface is via the menu "out". This allows the user to adjust the interface parameters to the requirements of the individual electrical installation. In the selection menu there are different baud rates from 1,200 to 115,200 baud. The factory setting is 19,200 baud. The bus address is selectable from 3 to 247 and the parity is adjustable between "even", "odd" and "none".

The devices can thus be used without another gateway in a Modbus RTU environment. ■

*Dipl.-Ing. Frank Mehlhng, T-MIS*

### The successor device

of the FTC470XDP is based on a new intuitive COMTRAXX® user interface, which with additional interfaces expands and improves the device communication.



### COMTRAXX® COM465DP:

## The New Gateway Generation

The protocol converter COM465DP transmits data of the BMS bus onto the PROFIBUS-DP, and vice versa. With the new, easy-to-use, HTML5 graphical COMTRAXX® based user interface, devices can be programmed more easily, more universally and barrier-free. It is also possible to integrate queries from Bender devices with communication possibilities, such as EDS, RCMS, MEDICS® or PEM systems and their information in a PROFIBUS-DP system. Whereas the previous model FTC470XDP only communicated via the BMS with the PROFIBUS-DP, the base unit of the COM465DP is already equipped with a new IP based BCOM functionality, which is the new communication interface for future Bender devices. In addition, it has other interfaces and can be expanded with additional modules as with the COM460IP. ■

Jan Hofmann, T-SCT

### Advantages of the new COM465DP:

- The latest COMTRAXX® user interface based on HTML5
- Device parameters can be set directly using the graphical user interface
- Integration of the Power Quality Devices (PEM) in PROFIBUS-DP infrastructure
- Existing interfaces:
  - RS-485-D-Sub: PROFIBUS-DP
  - RS-485: BMS, Modbus/RTU
  - Ethernet: BCOM, Modbus/TCP
- Functionality for mini-HDMI and mini-USB via software update coming soon
- 24 V version (soon available also as 230 V version).

### Communication options in comparison:

FTC470XDP	COM465DP
BMS - PROFIBUS-DP	Basic device: BMS/BCOM - PROFIBUS-DP
	<b>Expandable with functional modules:</b> <ul style="list-style-type: none"> <li>A – Individual texts, e-mail, device monitoring, reports</li> <li>B – Modbus/TCP full access and control commands, SNMP</li> <li>C – Parameter setting</li> <li>D – Visualisation, graphical representation of the data logger</li> </ul>



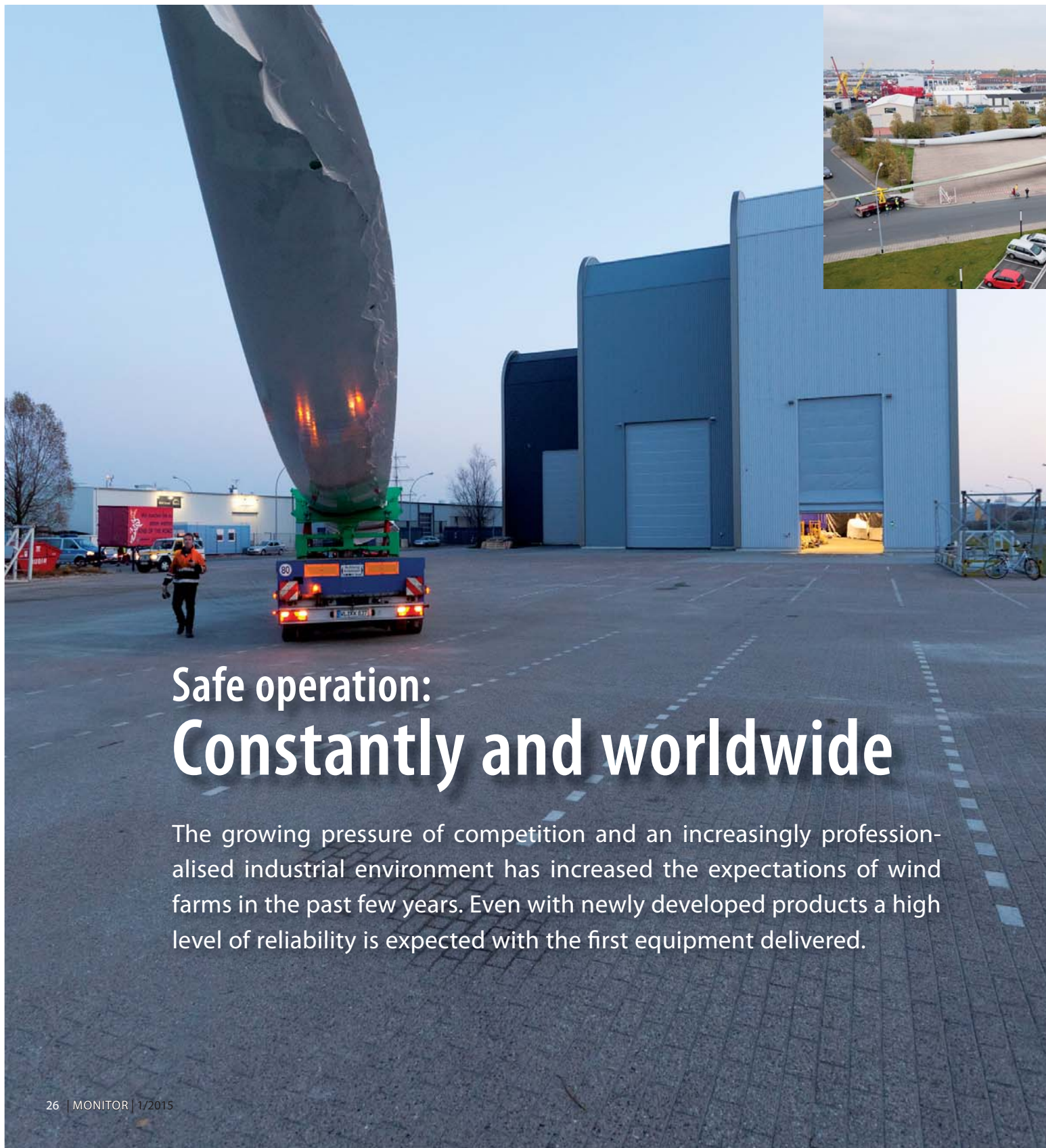

## Safe operation: Constantly and worldwide

The growing pressure of competition and an increasingly professionalised industrial environment has increased the expectations of wind farms in the past few years. Even with newly developed products a high level of reliability is expected with the first equipment delivered.

**"The constant movements** with a fatigue test which simulates 20 years of operation **demands a high-performance and resilient power supply."**



### Bender technology and profitable service – a good team

**The Fraunhofer IWES Northwest**, Institute for Wind Energy and Energy System Technology IWES, is part of the Fraunhofer Gesellschaft and deals with the physical and engineering aspects of wind electricity generation and usage. In this sector IWES Northwest offers equipment manufacturers, wind park operators, suppliers and the energy supply companies an effective co-operation for all technical issues, this also includes a unique testing infrastructure.

Wind turbine blades are the central components of wind energy systems and are subjected to diverse requirements. In order to check and validate the latest generation there is a rotor blade test centre in Bremerhaven, which has an infrastructure that can test blades up to 90 metres long. Depending on the scope of the test, the rotor blade is examined for several months. The longest rotor blade in the world (83.5 m) completed this test procedure in 2013.

Even though the checks can be carried out very energy efficiently by making use of the blades' natural frequency, the constant movements with a fatigue test which simulates 20 years of operation demands a high-performance and resilient power supply.

Bender installed a Power Quality Device PEM575 on site along with a residual current monitoring system RCMS460-D, which are both used to monitor the residual current and the operating currents of all eight electrical motors in the supply units that provide the entire energy for testing the rotor blades of one megawatt. Within the scope of a Bender Remote Assist contract these devices and systems are monitored, documented and evaluated. This places safety and customer-oriented technical support at the highest level.





## TECHNICAL APPLICATION

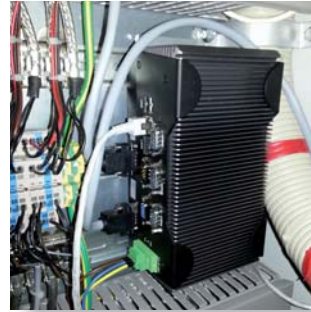

Gateway COM700RA

### Bender Remote Assist



### THE ADVANTAGES WITH BENDER REMOTE ASSIST:

- Increased operating safety
- Technical support anytime, anywhere
- More effective and enhanced service
- Saves time and costs.

### Having everything in sight!

An important component for Bender Remote Assist is the Gateway COM700RA, which was specially developed for the safe connection of the installation to the service platform. It is simply connected to the device communication interface that is already present in the system. Using the on site Bender devices, sound conclusions can be made concerning the network quality, any occurring malfunctions and possible alarm situations. The extensive documentation and visualisation of the system available via the Gateway help with the orientation even in an alarm situation. Within the scope of a so called regular remote maintenance, evaluations of the system take place, also offered are different trend analyses, which supply information on the condition of the available resources. Of course, with the highest safety standard that is available.

The installation of the Bender Remote Assist opens up a wide spectrum of services. This allows Bender to provide the Fraunhofer IWES with the entire technical know-how and reliable support in the safe operation of the system. Constantly and worldwide. ■

*B.Eng. Michael Breuer, S-SER*

The traditional Naturmuseum Senckenberg  
**relies on unearthed power supply**

TECHNICAL APPLICATION

# The Stone Age meets modern network protection technology

**In one of the largest natural history museums in Germany,** irreplaceable exhibits need to be protected against fire. At the same time, the costs to fulfil accident prevention regulations are very high. In order to reduce costs and increase fire safety in its most famous museum, the Senckenberg Natural Research Gesellschaft has opted to use insulation monitoring devices from Bender.

The Naturmuseum Senckenberg in Frankfurt am Main is internationally renowned. Virtually all school-children in the Hessen region have visited this traditional museum at least once. But what is less known is that the Senckenberg Gesellschaft für Naturforschung (SGN) Senckenberg for short – also carries out comprehensive research into bioscience and geoscience.

The emphasis is on research into biodiversity, evolution, the ecosystem and human interaction with the earth.

Senckenberg is the governing body of a total of six research institutions at ten sites across Germany and three natural history museums in Frankfurt am Main, Dresden and Görlitz.





## TECHNICAL APPLICATION

▶▶▶ 6000 square metres of natural history



The Naturmuseum Senckenberg Museum in Frankfurt am Main covers 6000 square metres, making it one of the biggest natural history museums in Germany. Exhibitions and museums are the shop window of natural research through which Senckenberg shares the latest scientific findings with its visitors and gives an insight into times gone by. Senckenberg shares research and research findings from all areas of biology, palaeontology and geology with the public through the medium of rare, often spectacular exhibits such as dinosaurs. Alongside the museum's educational programme, special exhibitions on changing themes, presentations and events supports the permanent exhibitions at the Senckenberg Nature Museum.



Spectacular exhibits ...

The highlights of the permanent exhibition include the fossilised "Dinosaur mummy" of an Edmontosaurus, a capybara-eating anaconda or a reconstruction of the skeleton of 'Lucy', the mother of the modern human. Visitors to the Senckenberg can also admire the skeletons of huge mammoths and the ancient foal from the UNESCO World Natural Heritage excavation in Messel, stand in the stomach of a fin whale or discover glittering stones in the darkness.



... require special protection

Every exhibit tells its own little story and gives an impression about the time and the place it came from. And it goes without saying that these unique, highly valuable objects need extra-special protection, especially against fire, because they are one-offs and irreplaceable.

In the collection storage of the Institute in Frankfurt am Main products from around the world are available for research purposes. More than 22 million objects are stored, which are available as references for about 200 visiting scientists each year. The Senckenberg Research Archive is therefore one of the most important collections of its kind. In the workshop for taxidermy it is clear to see how the exhibits of the museum is "brought to life".

Electrical insulation faults  
are the number one cause of fires.

A comprehensive operational readiness around the clock requires a high degree of electrical safety with the power supply. Even with careful planning, execution and maintenance: Electrical installations are always at risk – moisture, ageing, dirt, mechanical damage or other errors can never be completely ruled out. Undetected insulation faults can have





disastrous affects or lead to high costs, for example for repairs, replacement of devices or unplanned service calls.

Goal of every operator must be to detect faults in time and to eliminate the causes economically in order to achieve optimum plant and operational safety and ultimately reduce costs. One solution is the unearthed power supply (IT system) with insulation monitoring.

## Reliability and fire protection

In IT systems there is no active conductor connected to earth. When an insulation fault occurs, only a small amount of leakage current can flow and this is mainly due to the system leakage capacitance. The upstream fuse does not respond, the power supply is not affected which ensures continued operation. The immediate information on potential risk is performed by an insulation monitoring device, the ISOMETER<sup>®</sup>, which continuously monitors the insulation resistance between earth and system.



Due to these considerable advantages – maximum safety at minimal cost – the installation of the collection storage is implemented with two unearthed IT systems. Both the AV system (normal power supply) and the SV system (safety power supply), were built as three-phase AC systems and are monitored by means of an ISOMETER<sup>®</sup> from the series IRDH260. In the SV system the control of the fire alarm system and CO<sub>2</sub> extinguishing system are continuously monitored.

Besides the increased reliability the fire alarm system was a key point for the decision to install IT systems in the deep storage. In IT systems, there are no earth fault currents that pose a significant risk of fire.



### Collected knowledge:

In storage at the institute in Frankfurt am Main is a collection of specimens from all over the world which are available for scientific research.

The total number of collected items is estimated to run into millions.

## Prevention instead of intervention

For the operational safety and maintenance costs, the ISOMETER<sup>®</sup> offers the operator of the Senckenberg Naturmuseum the additional advantage of permanent monitoring, even with disconnected loads. In addition, the cost-intensive test intervals are no longer required, as prescribed for earthed systems.

This means that the exhibits, some of which are a million years old and irreplaceable can look forward to a secure future thanks to the electrical safety technology from Bender. ■

*Dipl.-Ing. Heiner Carnein, Tech. Office Hesse  
René Bülow, S-SER*

## INCREASE SAFETY, REDUCE COSTS

Compared to the known and widely used earthed systems (TN and TT systems) the IT systems provide numerous other advantages, the most important are:

- **Optimised maintenance:** Detect and report insulation deterioration at an early stage
- **Improved fire protection:** Recognise gradually developing insulation faults early; minimize arcing faults which are a frequent cause of fire
- **Higher efficiency:** Reduce time and personnel expenses for maintenance; detect weak points in the installation
- **Higher reliability:** No operational interruptions due to single-pole earth faults; installations remain at a high level of availability.



### Proven technology for electrical safety

is now also finding its way to Mongolia



## Upheaval in health care



**As in many developing and emerging countries,** health care in Mongolia is also being modernised. The "United Family Intermed Hospital" in the Mongolian capital Ulaanbaator is the first modern hospital to be placed in operation in the country. For electrical safety in the hospital, products from Gruenberg, the headquarters of Bender are used.



The ever-advancing standardisation of safety guidelines, also at international level, requires reliable, standardised solutions for installations and building systems. Although at the present time neither of the two standards most widespread internationally, IEC or NFPA, has been officially adopted in Mongolia, the IEC standard is now taken as the basis for new construction.

### Western standard in developing countries

The privately financed United Family Intermed Hospital in Ulaanbaatar is the first hospital in Mongolia that has been equipped with medical infrastructure to Western standards. These days modern medical infrastructure signifies a highly complex electrical and electronic environment for which reliable supply technology and electrical safety technology is imperative to protect people and equipment.

The complete new hospital was built in only three years under the leadership of the Austrian VAMED Engineering GmbH & Co. KG. In relation to its technical equipment and infrastructure, the hospital project is in no way inferior to new hospitals in the West. The safety standards for the power supply had to be met as did the requirements on the highly complex electronic medical systems and equipment.

### Proven partnership

Modern medical installations with the involvement of German companies: The fact that this approach is effective in practice has in the meantime also been acknowledged in Mongolia. The good experience obtained with German engineering, with the quality of German planning and with German know-how is time and again a decisive criterion for the involvement of German companies and the usage of German technology in new construction projects.

In the middle of 2014 the United Family Intermed Hospital in Ulaanbaatar was placed in operation – a highly modern hospital with four operating theatres and several rooms in the intensive care unit. The new operating theatre block and the intensive care stations integrate seamlessly into a large number of other rooms that have been equipped with the latest diagnostic and treatment features for almost all relevant medical disciplines.

The hospital is designed for 5,000 inpatients and 100,000 outpatients. In total more than 240 staff are employed in the hospital, these include 40 highly qualified specialists and consultants.

### Highest requirements

In the United Family Intermed Hospital value is placed on the above-average quality of the medical services as well as the usage of the latest diagnostic and treatment methods. At the same time, every effort is made to make the patients' stay in the hospital as pleasant as possible. Comfortable wards, a balanced diet, large, pleasant rooms, cleanliness, well-kept quiet zones and zones in which patients can recover optimally are therefore a matter of course.



### AN OVERVIEW OF THE UNITED FAMILY INTERMED HOSPITAL:

- 91 beds, which are available around the clock
- 15 specialist departments, including paediatrics, gynaecology, ear, nose and throat, dental medicine, internal medicine
- Emergency room, trauma and general surgery and an intensive care station
- Reanimation department
- An adjacent prevention centre with numerous facilities for preventive medical check-ups
- Computer tomography (CT)
- Magnetic Resonance Imaging (MRI).



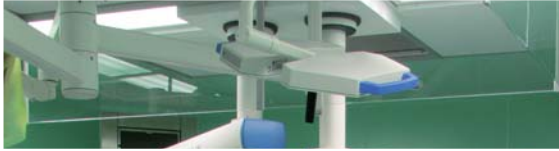

## TECHNICAL APPLICATION

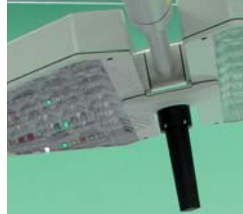

- Installation of the proven Bender measuring device interface (BMS) to provide all the necessary information for the medical and technical personnel at two central nurse's stations
- Installation of a BMS Ethernet Gateway COM460IP for the connection of the BMS to TCP/IP networks
- 5 air conditioning control cabinets, equipped with SIEMENS S7 controller, SIMATIC HMI TP700 7 touchscreen and VPN access for the complex monitoring and control of the ventilation system in conjunction with the series TM panels installed in the operating theatres, also using remote access and from Germany.

### ▶▶▶ Strong together

Along with the usage of the latest medical technology supplied by well-known German and international companies such as TRUMPF Medizin Systeme GmbH & Co. KG, Dräger AG & Co. KGaA, MMM Münchener Medizin Mechanik GmbH, Siemens Ltd. Seoul, Karl Storz GmbH & Co. KG, Weiss Group, SAMSUNG MEDICAL ENG CO., LTD, etc. the BENDER Group is involved in the following protection and monitoring solutions for the building systems:

- Supply of all group 2 rooms, i.e. the complete supply of power for a total of four operating theatre modules and three intensive care stations with a total of 15 beds
- 8 combined TN-S/ IT system distribution boards, equipped with, among other items, a total of 12 IT systems, with completely automatic series ATICS-2-...-DIO and ATICS-4-...-DIO transfer switching devices, integrated series isoMED427P-2 insulation monitoring devices and the latest EDS systems EDS151
- 3 series TM panels with hygiene display and all the usual operating elements and controls for operating theatres
- 1 hygiene version series FM panel
- 15 series «MK2430-11» indicator panels
- 4 series «AT» indicator panels (version with glass cover) for displaying the messages «OPERATING THEATRE IN USE»



### Straightforward and safe

Particularly in medical locations in countries such as Mongolia, the proven technology used in Bender EDS systems (insulation fault location systems in unearthed power supply systems) still satisfies the complex requirements of today. With their assistance the user can quickly find the location of the insulation fault caused by electrical medical equipment, or parts of the installation.

The operating theatre panels from the esb series TM have become basic equipment, as the entire contents of their alphanumeric displays can be changed into any language, including Mongolian.

### Solutions for complex challenges

The example of the United Family Intermed Hospitals is one of a large number of projects worldwide that show how Bender is able to meet complex requirements in the area of building systems, in particular for electrical safety. With technology always orientated on customer requirements and local conditions, there is always a solution for every challenge – not only in health care. ■

Thomas Gans  
Technical office Moscow

With insulation fault monitoring and **portable fault location systems** the United States Coast Guard always has the right combination on board.



## Always travel safe – with a reliable power supply

**The United States Coast Guard** is a branch of the United States Armed Forces. It is a military service unit with the purposes of maritime law enforcement along the domestic water ways surrounding the USA. Their duties incorporate but are not limited to homeland security, law enforcement (e.g. seizure of drugs), search and rescue and intracoastal and offshore aids to navigation. Using Bender technology on board, the crew can count on reliable power supply. >>>





## TECHNICAL APPLICATION

▶▶▶ The USCG operates a variety of ships. One of them is the Sentinel class cutter, a patrol boat, (WPC). These 47m (154 feet) long ships were originally known as fast response cutters and are primarily used for rescue work and law enforcement. Such a vessel can sometimes be for weeks at sea under all kinds of weather conditions. To ensure proper operation of its electrical system at all times, vital electrical circuits are designed as unearthen power supply systems (IT system) and require constant insulation monitoring. While working with the USCG and the shipyards, the Bender insulation monitoring device ISOMETER® IR425 had been chosen to monitor the DC 26 V onboard control circuits.



ISOMETER® IR425



ISOMETER® IRDH275

Very soon though intermittent alarms showed up and confused the operators as to where the health of their electrical system truly stood. Bender was called to provide training and evaluate the situation onboard. The USCH cutter William Flores was chosen for the meeting and investigation.

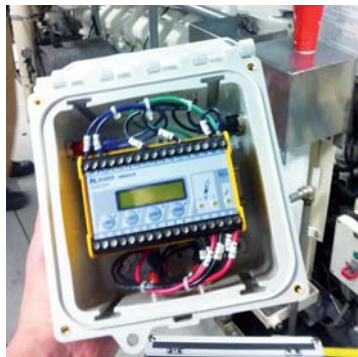

### Well equipped with the ISOMETER® IRDH275

After reviewing the wiring diagram it became clear that the electrical system was not only wide spread, but that it was also intertied between port and starboard side. A load profile was established and it was concluded that the overall resistance of a typical healthy DC system was below 30 kOhms. In response, it was decided to select the insulation monitoring device ISOMETER® IRDH275. The ISOMETER® is significantly more flexible due to increased functionality and a large variety of adaptation options. This results from the load profile and the reading from the IRDH275 monitor matched perfectly and the new solution was accepted.

### EDS3091 – a solution with a difference

Bender also had brought a portable equipment for insulation fault location EDS3091 to the meeting and was presented as the most suitable solution for the fast localisation of faults in unearthen power supply systems. The EDS3091 contains all the necessary components, such as the insulation fault locator EDS195P, the locating current injector PGH183 and the measuring clamp PSA3352 in



The EDS3091 and ...

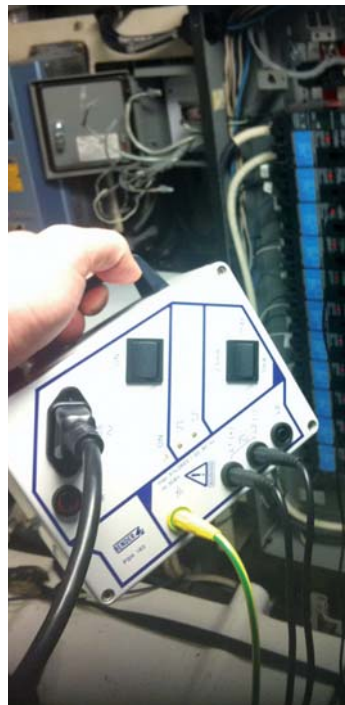

... the locating current injector PGH183 in use

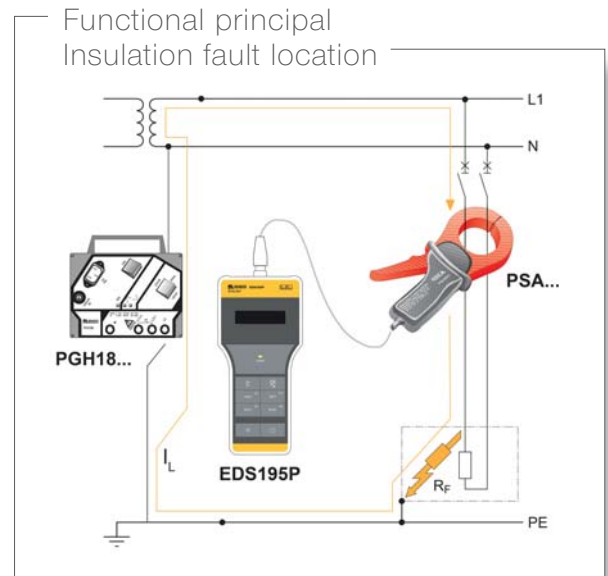

a robust easy-to-transport aluminium case. This was first met with skepticism since traditional fault finding requires that the system parts must usually be switched off one after another.

A test was set up where a controlled earth fault was hidden on one of the ships sensors. Indeed, the temporarily connected IRDH275 reliably alerted the “defective” earthed sensor. The locating current injector PGH183 was connected to the electrical system in the machine room. The test pulse emitted was quickly detected by the measuring clamp PSA3352 and displayed on the EDS195P.

Using the clamp tracing the test pulse from one electrical service panel to the next it took us less than an hour to find the fault. During this time, the ship was continuously supplied with electricity, it was not necessary to switch off the power.

The USCG was so impressed by the speed at which the EDS3091 is capable of localising faults, that they decided to acquire this solution for each ship.



EDS3091

It is worth mentioning that the combination of insulation monitoring and portable fault finding not only ensured a more reliable and stable DC supply system, but that the downtime due to strenuous fault finding attempts will be significantly reduced. ■

*Torsten Gruhn, Nathan Leonard  
Bender Inc., USA*



BENDER **INHOUSE**

## Bender UK sets standard for operating theatre installations

**Three projects spanning** the creation of new operating theatres at a private medical facility on Merseyside, and at hospitals in Sutton Coldfield and Barrow-in-Furness demonstrate the standard being set by Bender UK.

The company created the benchmark for isolated power supplies (IPS) and uninterruptable power supplies (UPS) installations in the clinical sector to safeguard patients, staff and medical equipment. Bender UK has built on that electrical expertise and developed a turnkey capability for installation of complete operating theatres.

The company's background as a leader in electrical safety products gives it a special insight into the complexity of the projects, enabling Bender UK to take a holistic view of requirements.

Managing director Steve Mason explains: "Developing expertise in the installation of operation theatres and equipment was a natural extension

of our commitment to the clinical sector. We can now offer a turnkey service from resilient IPS and UPS systems, through to the service pendants, control systems, advanced surgical lighting and ultra clean air canopies."

"Bender UK is in a unique position to advise healthcare facilities management professionals on options for creating new facilities or upgrading existing theatres. For example, Bender is the only supplier to provide a power changeover solution designed to the Safety Integrity Level (SIL) Level 2 standard (BS EN61508). Our award-winning ATICS® system is purpose-designed for medical applications with patient safety at the core of its conception and development."



Steve Mason







- ▶▶▶ The new £ multi-million private healthcare facility at Newton Le Willows owned and operated by Pall Mall Medical provides a perfect blueprint for Bender UK's turnkey capability.

Bender UK was engaged by medical specialists Planet Construction (UK) Ltd to supply, install and commission the operating theatres which occupy the top storey of the new building. The main operating theatre presented a significant challenge to

achieve the highest standards of clean air flow due to restricted space. However, the choice of the advanced performance canopy from ADMECO enabled the installation to optimise clean air flow to achieve the highest NHS standard and compliance with UK HTM03-01A.

Bender UK supplied and installed Steris LED surgical lighting in both theatres, and hygienic touchscreen control panels, along with service pendants for the endoscopic theatre. The installation also included the building's IPS and UPS systems serving the operating theatres, ground floor consulting rooms, and first floor facilities including imaging suites with MRI, CT, X-ray and Mamography facilities in addition to en-suite bedrooms.

State of the art lighting and electrical protection systems supplied and commissioned by Bender UK enhanced performance of a £300,000 ultra clean-air theatre for carrying out orthopaedic implant surgery at Furness General Hospital in Barrow-in-Furness.

Bender UK installed IPS and UPS systems, the theatre control panel and Steris advanced energy efficient XLED Operating lamps, for which Bender is the sole UK distributor.

Steris XLED adds a new dimension to the surgical lighting concept with its innovative LED design optimising the light for even illumination and elimination of shadows. With hygiene and infection control driving the upgrade, the lighting system included Bender's unique theatre control





wall-mounted touchscreen with a special anti-bacterial finish infused with silver ions, which enables staff to operate the controls even when wearing surgical gloves.

Bender UK was commended for the high levels of service it displayed on a £5.5 million project to create two state-of-the-art laparoscopic theatres at Good Hope Hospital in Sutton Coldfield.

Theatre 7 is a multi-functional gynaecology theatre used for endoscopic as well as laparoscopic surgery, while Theatre 8 is dedicated to minimally invasive gastro-intestinal surgery carried out using high definition video cameras.

Interserve, the main contractor on the project, commended Bender UK for the supply installation and commissioning of IPS systems with EDS insulation fault detection, and UPS units for each of the theatres.

Bender UK also equipped each theatre with anaesthetic and surgical services pendants, Steris XLED Operating Lamps, and theatre control panels with networked clock facility. Concurrently with the theatre project Bender UK installed and commissioned new IPS power and UPS systems for an Emergency Department at the hospital.

Also following our current marketing strategy, Bender UK is playing a key role in ensuring the authenticity of the operating theatre scenes in the new Sky T.V. drama Critical. We have provided operating theatre equipment for the film sets built for the series.



**FOR INFORMATION ON THE COMPANY'S  
CAPABILITIES FOR THE CLINICAL SECTOR VISIT**

[www.bender-uk.com](http://www.bender-uk.com)

Each programme in the 13-part medical drama will focus on the team's real-time efforts to save patients during the critical first 60 minutes after they arrive at the hospital, and those minutes will flash by in the digital clock on the Bender UK touchscreen control panel which controls operating theatre equipment.

Bender UK operation manager Gareth Brunton explained: "The team producing 'Critical' wanted total authenticity in the state of the art operating theatre which is the centre of the action. As a turnkey provider of operating theatre solutions and equipment to medical facilities across the UK we were happy to work with them, supplying the Steris XLED theatre lighting and the Bender hygienic touch-screen panel controlling theatre functions and of course displaying the all-important digital clock to track the race-against-time action." ■



Gareth Brunton

*Chris Nelson, Bender UK*



## PRO-MAC

# A long lasting cooperation with Bender

PRO-MAC was established by Maciej Sałasiński as an electrical design office in 1991. Headquarters is located in Lodz, in the center of Poland, with a branch in Gdynia, a city of the Baltic Sea.

We are partners for well-known foreign companies, foremost Bender as a manufacturer of insulation monitoring devices for power grids in the industry, hospitals and other public buildings. Our activities cover the whole territory of Poland. We have solid relationships with customers in many different industries and in hospital sectors. In medical applications our main customers are public hospitals. In industrial fields we are penetrating in mining, chemical and energy industries that require advanced safety.

We are dealing directly with managers and operating personnel. We advise and assist customers from planning through delivery and installation to service and technical support.

We also have our own production of cabinets and modules for medical locations. This allows us to flexibly adapt to the specific needs of the customer.

### Our success story

The cooperation with Bender started in 1994. In the beginning of this cooperation, particular emphasis was placed on promotion of acquiring knowledge about European / German standards and possible technical solutions among Polish designers and users of medical installations. During the years this work initially created informal, and after Poland became a European Union member, formal standards for such installations. This way of cooperation i.e. first seminars and presentations of



possible technical background, standards and engineering rules and then possible solutions and preparing offers and sales, is still a basic way of work allowing PRO-MAC to establish long term cooperation with many customers and keep the position of technical leader of the market.

Except hospital markets, we started our activities in the industry. First business relations PRO-MAC had in energy sectors were: power plants, cogeneration plants and paper factories. Gradually our activities in the next industry sectors were started: black and brown coal mines, steel plants, petrochemical and chemical factories, shipyards and many other plants all over the country.

## Strong Team

The rising number of contracts, meetings and turnovers caused the need for new things. In the following years new people were employed in and outside of Lodz: five engineers are working as regional representatives and three new departments were provided – service, logistics and a small production department for distribution boards – mainly for hospital projects. Currently we have a total of 20 employees. Regional managers establish and maintain



contacts with customers and potential customers. They visit companies and designers to identify their needs, to demonstrate new products, to leave catalogues etc.

Product engineers participate in the training courses in Gruenberg and have good technical knowledge. They help customers to specify products applicable to their requirements and give them technical support.

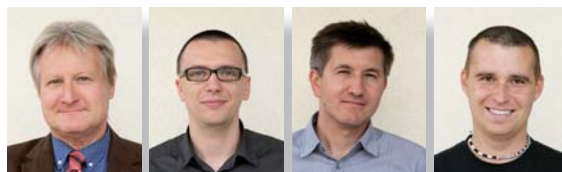

Maciej Salasinski   Marek Bojakowski   Jarek Mielczarek   Piotr Kozlowski

The continuous growth and the growing number of employees forced us to move in 2011. The grand opening of the new office building was combined with the celebration of the 20th anniversary of our company. It was a great opportunity to meet directly with our partners and customers.







### ▶▶▶ Promotional activities

As a Bender representative we run a number of promotional activities and build long-lasting relationships with customers. We organise seminars in different locations for decision-making and technical staff of hospitals and designers. We also organise workshops for employees of a selected company in order to familiarise them with our offer and to demonstrate the benefits of using Bender products.

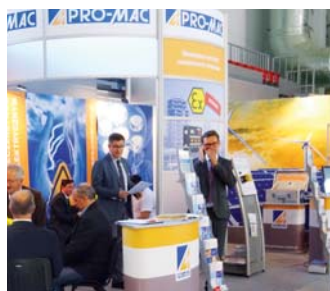

The sales are supported by articles in journals and on industry portals. Another way to promote Bender products, to meet customers and spread information, are trade shows and related seminars. We have catalogues, brochures and demo panels in Polish. We also provide search engine advertising in Google AdWords.

### About projects

During more than 20 years of collaboration with Bender, a very large number of projects have been realised. Mainly in hospital sectors and in industrial fields.

### Hospital

The beginnings of PRO-MAC activities in Polish markets with Bender products were monitoring devices for the power supplies in hospitals. First these were analogue UMC107 modules, then digital UMC107E modules and today these are ATiCS® transfer switching and monitoring modules. Through all the years, solutions offered by PRO-MAC were recognised as state-of-the-art in this field. Simultaneously, thanks to our seminars and presentations, new possibilities offered for hospitals like insulation fault location, residual current monitoring in the TN-S part of a system, TM panels and communication solutions became standard solutions for all new and modernised hospital installations. Today, Bender products are present in hundreds of medical distribution boards all over Poland.

#### Some major hospital projects in 2014 are

Hospital in Białystok – (ATiCS + MK2430+RCMS460)

Hospital in Szczecin Zdunowo - (ATiCS + MK2430)

Barlicki Hospital in Lodz (ATiCS + MK2430 + RCMS460).





## Industry

The first industrial customers were power plants and cogeneration plants. They have used insulation monitoring devices ISOMETERS® and insulation fault location systems in DC 220 V control systems, which supplying all control and measuring systems is critical to all productions. Today, all Polish power plants and many cogeneration plants are using these systems. Last year's EDS system became popular in the distribution part of power plants. Depending on the size of DC 220 systems, last year's stationary or portable EDS systems became standard equipment for many energy supply companies.

Meanwhile, insulation fault location systems are used in all Polish power plants. In the largest lignite-fired power plant in Bełchatów (capacity: max. 5.3 GW) ISOMETER®s in combination with EDS systems monitor DC 220 V systems in six blocks with 200 outlets each. A typical large-scale power plant, e.g. 220 kV/15 kV, needs two DC 220 V distribution boards with 80-120 outlets. Sometimes the system is bigger and can need even over 200 or even 400 outlets. Due to the high-voltage distribution board (110, 220, 400 or 750 kV) working with minimum staff, an effective communication with the power provider is essential. Upon request of PSE (Polskie Sieci Elektroenergetyczne – Polish power mains), we came up with a gateway that converts BMS to IEC 870-5-103 communication protocol used for all control systems in high-voltage distribution boards of the PSE.

EDS systems work in all Polish power plants – one of them is the world's biggest brown coal power plant in Bełchatów (max power 5,3 GW). EDS control DC 220 V systems in 6 blocks, monitoring over 200 outlets in each.

Another important industry sector where PRO-MAC has a big number of customers is the mining industry: black coal, brown coal and copper mines. As standard 3 AC 500 V unearthed power supply systems (IT systems) are used there which are monitored by an insulation monitoring device ISOMETER®. For insulation fault location, EDS systems in combination with AGH505 coupling devices are used to fulfil special mining regulations. Power supply systems in mines are sometimes very spread out over big terrain and it forced us to use non-standard solutions: for example, to keep communication between EDS system components in sub-distribution



boards in the black coal mine of Pniówek, we had to use fibre-optic cables instead of copper wires.

Another big customer who PRO-MAC cooperates with is one of the biggest copper producers KGHM. ISOMETERS®, EDS and RCMS systems are installed in his copper mines and copper plants.

PRO-MAC is as well-known and present with Bender devices as in other industry sectors like chemical and petrochemical factories (Orlen, Anwil, ZA Police, ZA Puławy) in steel plants (Arcelor Mittal steel plants in Krakow and Dabrowa Gornicza), PKP Energetyka, PGNiG. Another interesting customer is the Polish military harbour in Gdynia and Swinoujscie.

Last year we developed a market of earthed systems (TN-S system) with RCM and RCMS residual current monitors. We have several applications in office and public buildings (concert hall, museum, kindergarten and even in jail).

We developed cooperation with big players of electrical markets: our regular customers are firms like GE, ABB, Siemens, Schneider Electric.

Our success would not be possible without the high quality, innovation and reliability of Bender products. We also would like to express our thanks to all Bender staff for the technical and marketing support. ■

*Maciej Salasinski, PRO-MAC, Polen*



## Schalt-Technik Huber represents service and expertise

**As a family company with almost 50 years experience,** we know the difference between pure service and genuine partnership. Holistic energy management calls for individual concepts. Close cooperation and taking on your special wishes and needs is an absolute MUST for us when it comes to the distribution, control and monitoring of electrical energy.



"The operative word with energy supply is **"Fail safety"**."

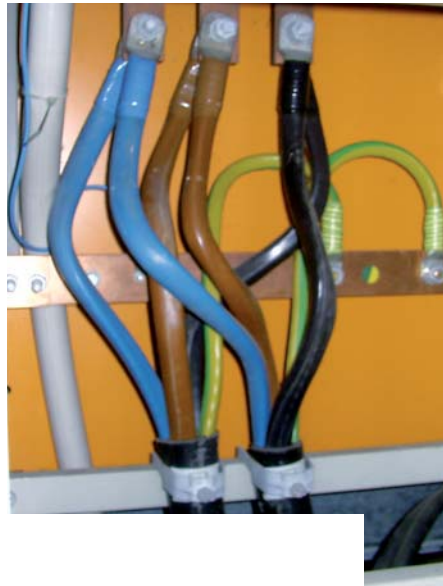

Retrofit: before ... .. and after.

**As SIVACON S8 technology partner** we are a qualified and continuously audited specialist chosen by Siemens, which always guarantees Siemens combined know-how for your low voltage projects.

## Switchgear

We did not invent the switchgear, but we are undeniably one of the first ever companies. Through our experience, we offer complete solutions from a single source.

You can take the smallest sub-distribution or switchgear with a nominal current rating of 7000 A. We accompany you with extensive consultancy right from the start, by taking over all necessary conversations with planning offices and/or utility companies, we make appropriate plans and produce according to your ideas.

## Energy supply

The operative word with energy supply is "Fail safety". Starting with the individual planning and going on to the turnkey handover, Schalt-Technik Huber applies only the highest standards. Our clients include data centres and hospitals. That speaks for itself!

## Retrofit

Shortly before noon, is not too late! Schalt-Technik Huber refurbishes individual cabinets or rebuilds your entire energy supply. We distinguish between refurbishment, repair and replacement. This enables economic solutions to be found - often just a partial renewal is all that is needed.

## Consultancy/engineering

It starts with an expert opinion and ends with the implementation. Service is more than just advice and maintenance! Service means safety, reliability, speed and accessibility - 24 hours a day.

Our emergency service is at your disposal 24 hours a day. During the week, at weekends and on public holidays. We are always there for you.



## CUSTOMER PORTRAIT

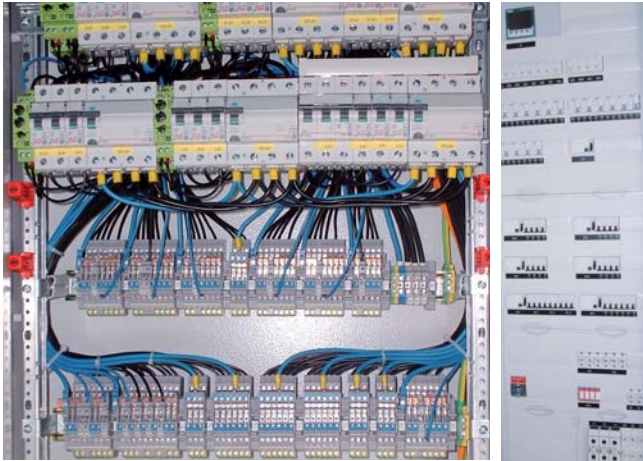

### ▶▶▶ Energy monitoring

Basic requirement for a transparent energy management system is the continuous and reliable measurement of energy. This information allows the identification of consumption, the analysis and finally the optimisation.

Therefore, many companies will have to deal with the introduction of an energy management system in the future. For this reason new electrical switchgear should be equipped with instrumentation. Existing equipment should be retrofitted.

The aim is to enable our customers to achieve a continuous improvement of energy-related services through a systematic approach which includes:

- **the energy efficiency**
- **the energy usage**
- **the energy consumption.**

**With the system components from the company Bender,** we offer comprehensive solutions in the area of energy monitoring. Reduction of interfaces through implementation of all required activities from a single source.

- Assessing the current situation, consulting, and creation of a catalogue of measures
- Installation of appropriate equipment in newly-made switchgear
- Replacement of existing equipment in existing installations (without disconnecting the electrical installation)
- Installation of transformers, voltage path taps and measuring devices in existing systems (without switching off the equipment)
- Required Ethernet or Modbus wiring
- Connecting the new Ethernet devices to the existing infrastructure wherever necessary
- Commissioning, operator training and documentation.

### Services

We are happy to take over the execution of engineering and/or installation services. The settlement is done over a package deal, or according to effort. Just talk to us about it!

### Our team

Providing our customers with the best performance is our top priority. This is something Schalt-Technik Huber guarantees with its many years experience and each individual employee with their effort and expertise. The principles of our company are professionalism, quality and reliability. ■

*Schalt-Technik Huber GmbH München  
www.schalt-technik.de*



# EXHIBITIONS 2015



## EXHIBITIONS INTERNATIONAL

### EXPONOR Chile 2015 – Mining exhibition

11.05. – 15.05.2015

Location: Antofagasta, Chile – [www.exponor.cl](http://www.exponor.cl)



### Railtex- NEC 2015

12.05. – 14.05.2015

Location: Birmingham, United Kingdom – [www.railtex.co.uk](http://www.railtex.co.uk)



### CHES – Ontario Chapter 2015

Event dates: 24.05.2015

Location: Ottawa, AB – Canada – [www.ches.org](http://www.ches.org)



### China ePower

12.05. – 15.05.2015

Location: Shanghai, China – [www.china-epower.cn/en](http://www.china-epower.cn/en)



### 16<sup>th</sup> Forum an Exhibition Introduction

20.05. – 23.05.2015

Location: Dalian, China – [www.chaej.com/chaej15/](http://www.chaej.com/chaej15/)



### Advancing Safety in Healthcare Technology (AAMI)

05.06 – 08.06.2015

Location: Denver, Co, USA – [www.aami.org/ac/](http://www.aami.org/ac/)



### ITEC

14.06. – 17.06.2015

Location: Dearborn, MI, USA – <http://itec-conf.com>



### National Fire Protection Association (NFPA) Conference Expo

22.06. – 25.06.2015

Location: Chicago, IL, USA – [www.nfpa.org](http://www.nfpa.org)



### Electric & Hybrid marine

23.06. – 25.06.2015

Location: Amsterdam, Netherlands

[www.elektrotechnik-online.nl/nl-NL/Bezoeker.aspx](http://www.elektrotechnik-online.nl/nl-NL/Bezoeker.aspx)



### ASHE Annual conference

12.07. – 15.07.2015

Location: Boston, MA, USA – [www.ashe.org/annual/#.VOyDyE05BI](http://www.ashe.org/annual/#.VOyDyE05BI)



### Intersolar exhibition

14.07. – 16.07.2015

Location: San Francisco, CA, USA – [www.intersolar.us/en/intersolar](http://www.intersolar.us/en/intersolar)



### Expo Hospital

22.07. – 24.07.2015

Location: Santiago, Chile – [www.expohospital.cl](http://www.expohospital.cl)



### SPE Oil & Gas

08.09. – 11.09.2015

Location: Aberdeen, United Kingdom – [www.offshore-europe.co.uk](http://www.offshore-europe.co.uk)



### Solar Power International

14.09. – 17.09.2015

Location: Anaheim, CA, USA

[www.solarpowerinternational.com](http://www.solarpowerinternational.com)



### Bluefield Coal Show

16.09. – 18.09.2015

Location: Bluefield, WV, USA

[www.bluefieldchamber.com/bluefield-coal-show](http://www.bluefieldchamber.com/bluefield-coal-show)



### CHES Canadian Hospital Engineering Society

20.09. – 22.09.2015

Location: Edmonton, AB, Canada – [www.ches.org](http://www.ches.org)



### Perumin

21.09. – 25.09.2015

Location: Arequipa, Peru

[www.convencionminera.com/perumin32/](http://www.convencionminera.com/perumin32/)



### Elektrotechnik

29.09. – 02.10.2015

Location: Utrecht, Netherlands

[www.elektrotechnik-online.nl/nl-NL/Bezoeker.aspx](http://www.elektrotechnik-online.nl/nl-NL/Bezoeker.aspx)



### RSSI Railway Systems Suppliers, Inc.

04.10. – 07.10.2015

Location: Minneapolis, MN, USA – [www.rssi.org](http://www.rssi.org)



### Healthcare Estates (IHEEM)

Institute of Healthcare Engineering and Estate Management

20.10. – 21.10.2015

Location: Manchester, United Kingdom

[www.healthcare-estates.com](http://www.healthcare-estates.com)



### Naval & Defence

20.10. – 23.10.2015

Location: Busan, South Korea – [www.marineweek.org](http://www.marineweek.org)



### FISE

20.10. – 23.10.2015

Location: Medellin, Colombia

[www.ferisectorelectrico.com.co/](http://www.ferisectorelectrico.com.co/)



## EXHIBITIONS NATIONAL

### Intersolar München – The world's largest Exhibition for Solar industry Event dates

10.06. – 12.06.2015

Location: Munich, Germany – [www.intersolar.de](http://www.intersolar.de)



### eCarTec

20.10. – 22.10.2015

Location: Munich, Germany – [www.ecartec.com](http://www.ecartec.com)



## INTERVIEW



### Dr. Carsten Bepler | Lawyer

#### Head of Legal Department

(law, patents, data protection and information security, compliance)

#### PROFESSIONAL CAREER

1990 – 1995	Studied law at Justus Liebig University in Gießen
1995 – 1998	Legal clerkship
1998 – 2001	Doctorate at the university of Rostock; bursary from the Federal Environment Foundation
2001	Qualification as solicitor; afterwards working in solicitors offices in Cologne, Frankfurt and Wetzlar.
2005 – 2009	In-house lawyer at TransMIT GmbH in Gießen
Since 2009	In-house lawyer at Bender GmbH & Co. KG in Grünberg

**Dr Bepler, it has become almost a tradition with these interviews to ask about your reasons for coming to Bender.**

I was excited by the prospect of setting up a legal department from scratch. It gave me real room for manoeuvre.

**As well as advising the company on legal matters, you are also responsible for compliance and data protection. How would you explain your work on compliance to the uninitiated?**

We should maybe start with the term 'compliance'. It is not hard to work out that the term comes from English and means 'adherence' or 'observation'. It means conformity with statutory and other legal regulations. The decision-makers are obliged to organise the company such that it is operated and managed in compliance with the statutory regulations. I am constantly advising them.

**There are completely different compliance rules in the service industry than in the finance and construction industry or the production industry in general, to which Bender also largely belongs. This differentiation is reflected, for example in the different specialist terms IT compliance, HR compliance and corporate compliance. What kind of rules and obligations are we talking about here?**

It is true that every industry has its own customs and its own legal "game rules". But corporate areas which are relevant to compliance can be identified for a large number of companies irrespective of their industry. These are:

- HR and employment law
- product safety
- corruption prevention
- anti-trust law
- data security and data protection
- environmental protection
- exports and customs
- tax.

**How do you prevent the rules being broken in the first place?**

There are now recognised standards in the compliance management sector. The first step is organisational instructions and monitoring that they are followed. One example for Bender is our gifts guidelines, which set out a framework for the giving and receiving of business gifts by our employees.

The second stage involves attempting to provide continuous professional development and training opportunities for the employees affected. Of course, as the compliance officer, I am always available to offer advice in individual cases.

**„Solid legal knowledge** in this area is of course indispensable as well as a certain degree of professional experience paired with knowledge of human nature.“

**When it comes to data protection, the questions on areas of activity must be considerably fewer than for compliance? After all, this mainly concerns the personal sector. What does data protection mean for a production company?**

Let me first say a word on personal data - i.e. the actual subject of data protection. In principle, this is any information which can be assigned to an individual. Even a production company like Bender has or collects a lot of information of this kind. It begins with its own employees, who often reveal extensive information about their private and work lives as part of the application process. The employees have the right to this data being handled in conformity with data protection laws. Or take the Customer Relationship Management system, for example. There need to be clear game rules on which information can be added to the system and which cannot. There is also the classic question of how specific people can be recruited. The legal situation here has changed many times in quick succession as part of the Federal Data Protection Act. The permissibility of the now ubiquitous video surveillance is another issue. This requires not only a level of sensitivity by the employer but also sound knowledge of data protection laws.

**International cooperation will increase in importance in future – which will involve increased levels of data and information exchange. The recent debate about the NSA scandal makes it clear that there are no consistent data protection standards. How do you handle this challenge?**

The activities of the NSA and other secret services is a big political issue and therefore not our concern. But people often confuse apples with oranges in this discussion. There is a difference between a government body accessing information in the public interest (in the fight against terror, for example) and someone hacking into private personal e-mail or account data to carry out criminal activities. However, the NSA scandal did make it clear that global data flows can be and are monitored. So I need to make a decision on a case by case basis as to whether this risk is acceptable to me or whether I should choose other communication methods or data formats.

**How do you make company employees more sensitive to data protection?**

First, we oblige our employees to comply with the Federal Data Protection Act as per the statutory regulations. As the data protection officer, I am, of course, available to answer questions on data protection. Systematic employee training is still required. To be honest, we still need to improve in this area.

**How do you get an overview of and keep up to date on data protection issues?**

I subscribe to a newsletter which includes data protection issues. Of course, as a lawyer, I work primarily with the letter of the law and refer back to the relevant commentaries and rulings in case of doubt. I also regularly take part in training courses.

**Dr Bepler, to conclude the interview, we would like to ask what the greatest challenges you face in the future are: What will be at the top of the compliance and data protection agenda over the next few years?**

Compliance will become a necessary part of all areas of business life. Against the backdrop of increasingly complex legal regulations and growing internationalisation with the resulting application of foreign laws, this is vital to the protection of the company and its employees. It has also become clear that non-compliant behaviour from companies can result in enormous economic damage. So there is real political pressure to drive the issue of corporate compliance further, with current proposals suggesting the introduction of a corporate penalty code.

In terms of data protection, there have been discussions on an ordinance to protect employee data within the EU for many years. The existing drafts keep getting rejected. It is important for this law to come into force at last.

Dr Bepler, thank you for the informative interview! ■

*Timothy Hörli, Dreipass*

# BENDER Group

The Bender Group with its main office in Gruenberg/Hesse has 70 agencies with approx. 670 employees worldwide.

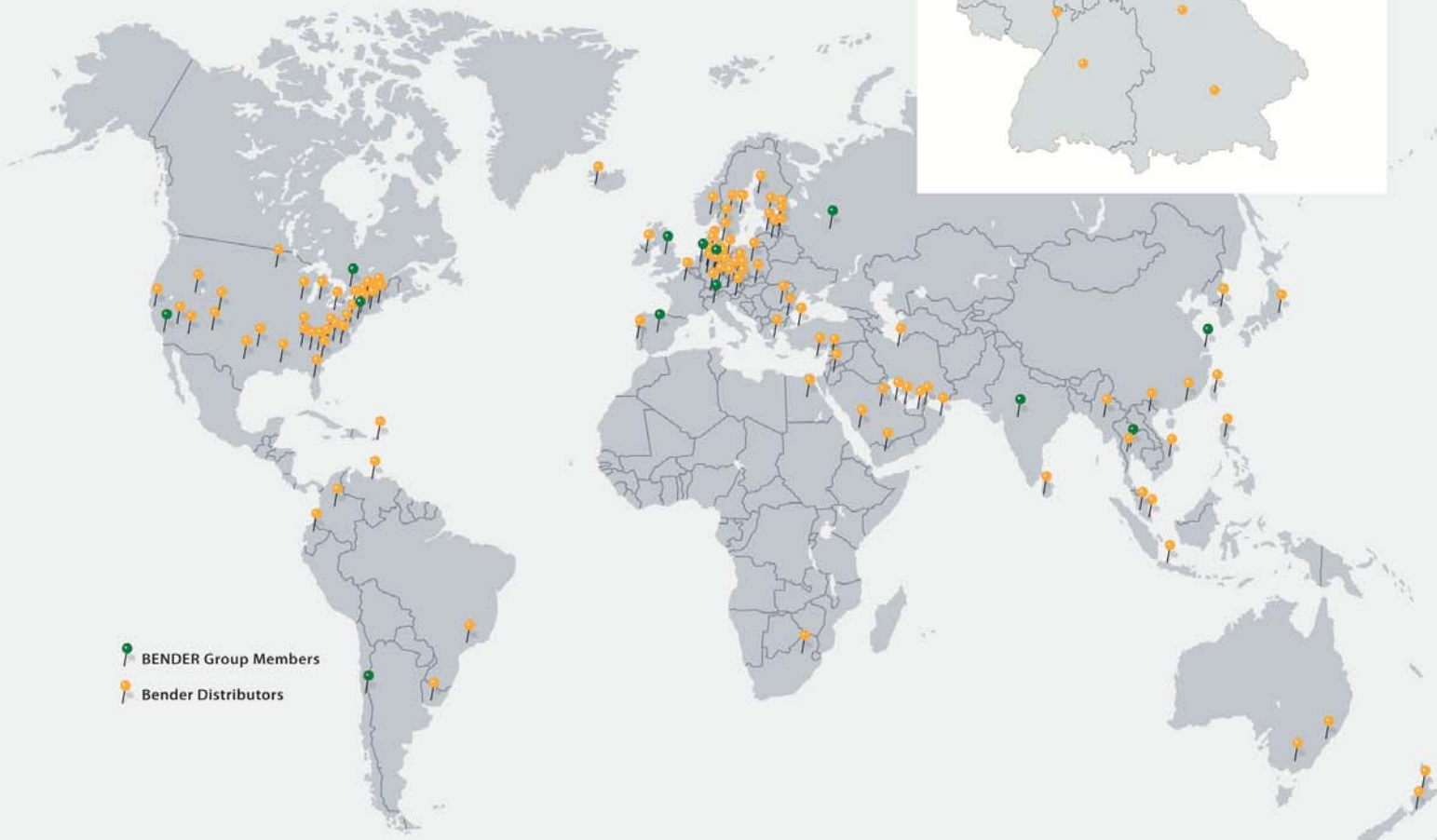

-  BENDER Group Members
-  Bender Distributors

Bender GmbH & Co. KG  
Londorfer Str. 65 • D-35305 Gruenberg / Germany  
Fon: +49 6401 807-0 • Fax: +49 6401 807-259  
E-Mail: [info@bender.de](mailto:info@bender.de) • [www.bender.de](http://www.bender.de)



BENDER Group

**Power in Electrical Safety**